

TOWNSHIP OF ABINGTON

(2) CODE ENFORCEMENT AND LAND DEVELOPMENT COMMITTEE

**March 2, 2015
7:00 P.M.**

CALL TO ORDER

**ROLL CALL: SANCHEZ - MARKMAN - DiPLACIDO - MYERS
 GILLESPIE**

**Township Manager LEFEVRE
Assistant Township Manager WEHMEYER
Township Solicitor CLARKE
Director of Code Enforcement MATTEO
Township Engineer POWERS**

MINUTES:

**Motion to approve the minutes of the February 2, 2014
Code Enforcement and Land Development Committee
Meeting**

**CE1. Subdivision SD-15-01 - James Sheridan - 1777 Kimball
 Avenue**

**Motion to approve the subdivision and land development
application of James Sheridan, applicant for the
property located at 1777 Kimball Avenue. The applicant
seeks approval to subdivide the property into three lots.
Lot No. 1 will contain the existing single-family dwelling
and consist of 22,640 square feet with frontage on
Kimball Avenue. Lots No. 2 and 3 are proposed for
development and are plotted at 7,662 square feet each.
Both Lots 2 and 3 have frontage on Smith Avenue. The
properties are zoned in the (R-4) Residential District in
Ward No. 8 of the Township of Abington.**

This motion is subject to the following conditions:

- 1. The applicant is required to provide the Township
with three (3) new executed, signed, notarized and
recorded deeds. This is a requirement of the
subdivision process.**

2. The applicant is required to set eight (8) concrete monuments as directed by the Abington Township Engineering Office.
3. Any work proposed within the roadway will require a "Highway Permit" from the Township Engineer's Office.
4. An escrow fee of \$15,500 will be required for the storm sewer and roadway improvements which includes the inspection fees.
5. All sanitary sewer pipes placed within the public right-of-way are required to be ductile iron pipe. Plastic/PVC pipe is not acceptable within the public right-of-way.
6. The applicant will install at the direction of the Public Works Department a new street light on an existing utility pole on Smith Avenue.

This motion is subject to the following waivers:

1. Waiver from Section 146-11.A-Property Identification Plan
2. Waiver from Section 146-11.B-Existing Features Plan
3. Waiver from Section 146-11.C-Proposed Layout Plan
4. Waiver from Section 146-11.L-Architectural Plan
5. Waiver from Section 146-27-Installation of Sidewalks on Kimball Avenue

CE2. *Land Development LD-15-02 – Molly Court Associates, LLC – 720 Rhoads Avenue*

Motion to approve the subdivision and land development application of Molly Court Associates, LLC, applicant and owner of the property located at 720 Rhoads Avenue. The applicants seek approval to demolish the existing structures on the site and subdivide the property into eight lots. A new road is proposed with access to Rhoads Avenue. The eight proposed lots will range in size from 15,098 square feet to 18,292 square feet. The applicant proposes to construct a new single-family dwelling on each of the lots. The properties are zoned within the (R-2) Residential District in Ward No. 3 of the Township of Abington.

This motion is subject to the following conditions:

- 1. The applicant is required to provide the Township with eight (8) new executed, signed, notarized and recorded deeds. This is a requirement of the subdivision process.**
- 2. The applicant is required to set eight (8) concrete monuments as directed by the Abington Township Engineering Office.**
- 3. Any work proposed within the roadway will require a "Highway Permit" from the Township Engineer's Office.**
- 4. The items listed within the Staff Review letter dated February 2, 2015 become a condition of the application.**
- 5. The applicant has submitted an ACT 537 Exemption application for the seven (7) new EDU's that will be required for this proposal.**

This motion is subject to the following waivers:

- 1. Waiver from Section 146-11.A-Property Identification Plan**
- 2. Waiver from Section 146-11.B-Existing Features Plan**
- 3. Waiver from Section 146-11.F.b-Street Plan**
- 4. Waiver from Section 146-11.1-Phasing Plan**
- 5. Waiver from Section 146-11.J-Recreation Facilities Plan**
- 6. Waiver from Section 146-11.L-Architectural Plan**

**Code Enforcement & Land Development
BOARD ACTION REQUEST**

March 12, 2015

CEI

Agenda Item

CODE ENFORCEMENT

TOWNSHIP MANAGER



**AGENDA ITEM
Subdivision SD-15-01
James Sheridan
1777 Kimball Avenue**

Handwritten signature

PREVIOUS ACTION:

- Abington Township Planning Commission approved this application with conditions and requested waivers on February 24, 2015.
- Montgomery County Planning Commission approved this application on January 15, 2015.

RECOMMENDED BOARD ACTION:

Motion to approve the subdivision and land development application of James Sheridan, applicant for the property located at 1777 Kimball Avenue. The applicant seeks approval to subdivide the property into three lots. Lot No. 1 will contain the existing single-family dwelling and consist of 22, 640 square feet with a frontage on Kimball Avenue. Lots No. 2 and 3 are proposed for development and are plotted at 7,662 square feet each. Both Lots 2 and 3 have frontage on Smith Avenue. The properties are zoned in the (R-4) Residential District in Ward No. 8 of the Township of Abington.

This motion is subject to the following conditions:

1. The applicant is required to provide the Township with three (3) new executed, signed, notarized and recorded deeds. This is a requirement of the subdivision process.
2. The applicant is required to set eight (8) concrete monuments as directed by the Abington Township Engineering Office.
3. Any work proposed within the roadway will require a "Highway Permit" from the Township Engineer's Office.
4. An escrow fee of \$15,500 will be required for the storm sewer and roadway improvements which includes the inspection fees.
5. All sanitary sewer pipes placed within the public right-of-way are required to be ductile iron pipe. Plastic/PVC pipe is not acceptable within the public right-of-way.

6. The applicant will install at the direction of the Public Works Department a new street light on an existing utility pole on Smith Avenue.

This motion is subject to the following waivers:

1. Waiver from Section 146-11.A – Property Identification Plan
2. Waiver from Section 146-11.B – Existing Features Plan
3. Waiver from Section 146-11.C – Proposed Layout Plan
4. Waiver from Section 146-11.L – Architectural Plan
5. Waiver from Section 146-27 – Installation of Sidewalks on Kimball Avenue

COMMENTS:

- *It is requested that the Public Works Department review the installation of a “No Outlet” or “Dead End” sign at the intersection of Smith and Windsor Avenues.*
- *It is requested that the Public Works Department review refuse collection for this street. The issue is how narrow the street is and that it is a dead end. The trucks have to drive in and back out multi times a week and these two new homes will double that truck traffic.*
- *It is requested that the Public Works Department review how the street will be plowed since there is no outlet and has homes on both sides of the street.*
- *A resident has requested that the Traffic Safety Officer review traffic flows on Kimball Avenue and permit two-way traffic.*

Matteo has committed to schedule a neighborhood meeting with the Smith Avenue residents and have a representative from the Engineering Office, Public Works Department and the Traffic Safety Office available to discuss the residents issues.

Township of Abington Planning Commission Recommendation Form

Application Number: SD-15-01

Date: February 24, 2015

Applicant's Name: James Sheridan

Applicant's Address: 1777 Kimball Avenue, Willow Grove, Pa. 19090

Recommendation: APPROVED DENIED VOTE: 6 of 6

Over View: This is the subdivision & land development application of **James Sheridan**, applicant for the property located at 1777 Kimball Avenue, Willow Grove, Pa. The applicant seeks approval to subdivide the property into three lots. Lot #1 will contain the existing single family dwelling and consist 22,640 square feet with frontage on Kimball Avenue. Lot #2 and Lot #3 are proposed for development and are plotted at 7662 square feet each. Lot #2 and Lot #3 have frontage on Smith Avenue. The properties are zoned within the (R-4) Residential District of Ward #8 of the Township of Abington.

Comments:

1. This proposal has the required two EDUs for the proposed new lots. Sanitary sewer service is available for this development as the flow from this proposal is not impeded by the sanitary sewer moratorium in place on flows through Cheltenham Township. An Act 537 Exemption Application will need to be approved for this development.
2. If this application is approved, the applicant is required to provide the township with three (3) new, executed (signed, notarized and recorded) deeds. This is a requirement of the subdivision process. The Township Engineer will not sign the plans without the required deeds.
3. The applicant is required to set (8) concrete monuments as directed by the Engineering Office of the Township of Abington.
4. The items listed within the Staff Review letter dated January 15, 2015 become a condition of this application if approved by the Board of Commissioners of the Township of Abington.

5. An escrow fee of \$15,000.00 is required to be submitted to the Township Engineering Office for the storm water management work proposed to be completed within the public right-of-way.
6. The Zoning Hearing Board of the Township of Abington approved the continuation of the on-site well for 1777 Kimball Avenue on August 19, 2014.

The following waivers have been requested.

- A. **Section 146-11.A - Property Identification Plan** – The plan is required to supply the tax parcel information, owner's name & lot area for all properties within 400 feet of the site(s) involved in this application. Staff supports this waiver. Yes {X} No { }
- B. **Section 146-11.B – Existing Features Plan** – The plan is required to plot the location of all utilities on the sites and within 400 feet of the properties involved in this application. Staff supports this request. Yes {X} No { }
- C. **Section 146-11.C – Proposed Layout Plan** – The plan is required to include first floor elevations, all existing utilities and all improvements on the site. Yes {X} No { }
- D. **Section 146-11.L – Architectural Plan** – The applicant is required to submit tentative architectural plans. The application has submitted a floor plan of the proposed new module home, however no elevation plans have been submitted. Staff supports this waiver request. Yes {X} No { }
- E. **Section 146-27 – Installation of Sidewalks** – The applicant has requested a waiver for the installation of sidewalks on the Kimball Avenue frontage. Staff supports this request. Yes {X} No { }
- F. **Section 146-38 – Street Lighting** – The applicant has requested a waiver for the installation of street light along the frontages of this development. Yes { } No {X}

Comments:

1. It is requested that the Public Works Department review the installation of a "No Outlet" or "Dead End" sign at the intersection of Smith & Windsor Avenues.

2. It is requested that the Public Works Department review refuse collection for this street. The issue is how narrow the street is and that it is a dead end. The trucks have pull all the way down the street and back out multi times a week and these two new homes will double that truck traffic.
3. It is requested that the Public Works Department review how the street will be plowed since there is no outlet and has homes on both sides of the street.
4. A resident has requested that the Traffic Safety Officer review traffic flows on Kimball Avenue and permit two way traffic.

Notes:

1. Mr. Matteo has committed to schedule a neighborhood meeting with the Smith Avenue residents and have a representative from the Engineering Office, Public Works Department and the Traffic Safety Office available to discuss the residents issues.

MAPenecale
2/24/2015



Wayne C. Luker, President
Steven N. Kline, Vice President
Michael LeFevre, Manager
Jay W. Blumenthal, Treasurer

1176 Old York Road Abington PA 19001-3713 Telephone: 267-536-1000

Subdivision & Land Development Notice Plan Review SD-15-01

Notice is hereby given that the Township of Abington will hold the following public meetings at the Abington Township Administration Building (1176 Old York Road) Planning Commission, Code Enforcement Committee and Board of Commissioners, to discuss the application of the **James Sheridan**.

MEETINGS	DATE AND TIME
Planning Commission Committee	February 24, 2015 @ 7:30 p.m.
Code Enforcement Committee	March 2, 2015 @ 7:00 p.m.
Board of Commissioners	March 12, 2015 @ 7:30 p.m.

This is the subdivision & land development application of **James Sheridan**, applicant for the property located at 1777 Kimball Avenue, Willow Grove, Pa. The applicant seeks approval to subdivide the property into three lots. Lot #1 will contain the existing single family dwelling and consist 22,640 square feet with frontage on Kimball Avenue. Lot #2 and Lot #3 are proposed for development and are plotted at 7662 square feet each. Lot #2 and Lot #3 have frontage on Smith Avenue. The properties are zoned within the (R-4) Residential District of Ward #8 of the Township of Abington.

The application and plans are on file in the Code Enforcement Department and may be reviewed upon request. If there are any questions and/or comments that you may have, please feel free to contact me at 267-536-1017.

Mark A. Penecale
Planning & Zoning Officer

- *These meetings are subject to change if additional review time is required by Township Staff or requested by the applicant.*





Wayne C. Luker, President
Steven N. Kline, Vice President
Michael LeFevre, Manager
Jay W. Blumenthal, Treasurer

1176 Old York Road Abington PA 19001-3713 Telephone: 267-536-1000

Joseph C. Kuhls, Esq.
500 Office Center Drive
Suite #400
Fort Washington, Pa. 19034

January 12, 2015

Re: Staff Review Comment on Application SD-15-01 for the property located at 1777 Kimball Avenue, Willow Grove, Pa. 19090.

Dear Mr. Kuhls,

This letter is written to inform you that the staff of the Township of Abington has reviewed the application and the plans submitted for the proposed subdivision of 1777 Kimball Avenue. The applicant proposes to subdivide the 37,964 square foot parcel into three lots. Lot #1 is proposed to contain the existing single family dwelling on a lot of 22,640 square feet. Lot #2 and Lot #3 will have frontage on Smith Avenue and be made up of 7,662 square feet each. This plan received Zoning Hearing Board approval on August 19, 2014 for the location of the existing well. Several of the conditions listed below are building permit related and will be clearly marked with a (BP). These comments are required be addressed at the time a building permit is submitted for review. All other comments must be addressed to the satisfaction of the Board of Commissioners of the Township of Abington.

Engineering:

1. This proposal is not affected by the DEP Sanitary Sewer Moratorium imposed by the Department of Environmental Protection. Sanitary sewers are available for the proposed two new lots. An ACT 537 Planning Module or Act 537 Exemption Certificate is required to be submitted in the event that permits for the construction of the two new single family dwelling are submitted.
2. If this application is approved, the applicant is required to provide the township with three (3) new, executed (signed, notarized and recorded) deeds. This is a requirement of the subdivision process. The Township Engineer will not sign the plans without the required deeds.
3. The applicant is required to install concrete monuments at any break or corner along the new property lines. This plan has eight (8) concrete monuments that will be required to be set. Iron pins are not permitted.



4. Any work proposed within the roadway will require a "Highway Permit from the Township Engineer's Office. This permit has the same base fee of \$65.00, plus \$1.00 per square foot. An escrow for extensive street work may be required.
5. An escrow fee of \$15,500.00 will be required for the storm sewer and roadway improvements which includes the inspection fees.
6. All sanitary sewer pipes placed within the public right-of-way are required to be ductile iron pipe. Plastic/PVC pipe is not acceptable within the public right-of-way.
7. A storm water management permit is required for the inspection of the construction of the required on-site storm water management system. This permit has a base fee of \$110.00, plus an additional escrow will be posted for the inspections of the system over a ten year period.
8. After the construction of the storm sewers, the applicant is required to mill and overlay the entire width of the roadway from the intersection to 100 feet past the end of the trench. Milling and the overlay will be done to the specification of the Township Engineer. Inspections for this work will be required.

Fire Marshal's Office:

9. No comments have been provide at this time.

Building Inspector:

10. The applicant proposes to construct two new single family dwellings. Permits will be required for the construction of the homes, the electrical, heating and air conditioning work proposed to be completed. (BP)
11. All work must comply with the construction and mechanical codes of the Township of Abington in place at the time of submission. (BP)
12. All contractors and subcontractors are required to be registered with the Pennsylvania State Attorney General's Office and a copy of that registration must be on file with the Code Enforcement of the Township of Abington. (BP)

Plumbing Inspector:

13. All plumbing permits must be submitted by a Master Plumber that is registered with the Code Enforcement Office of the Township of Abington. (BP)

14. All plumbing work must comply with the Plumbing Code of the Township of Abington in place at the time permits are submitted for review. (BP)

Planning & Zoning Office:

15. This application has been reviewed as a preliminary as final major subdivision and land development plan. The reason for this determination is the installation of the proposed storm sewer within the public right-of-way. This is a public improvement and the submission is a combination plan.
16. The required two additional EDU's are available for this development, however, the applicant is required to submit a DEP Planning Module Exemption Mailer.
17. This application received Zoning Hearing Board approval on August 19, 2014 for the placement of the existing well to supply water to 1777 Kimball Avenue.
18. An easement agreement is required for the proposed easement between Lot #2 and Lot #3 for the proposed storm water pipe. In addition, the building envelopes for both Lot #2 and Lot #3 will have to be adjusted so that the setbacks are measured from the outer edge of the easement and not the property line. Please refer to Section 801.C.8 of the Zoning Ordinance of the Township of Abington.
19. This plan conforms with all of the dimensional requirements of Section 304.3 of the Zoning Ordinance of the Township of Abington.
20. This application is required to obtain the following waivers from the Subdivision & Land Development Ordinance of the Township of Abington.
 - A. **Section 146-11.A - Property Identification Plan** – The plan is required to supply the tax parcel information, owner's name & lot area for all properties within 400 feet of the site(s) involved in this application. Staff supports this request.
 - B. **Section 146-11.B – Existing Features Plan** – The plan is required to plot the location of all utilities on the sites and within 400 feet of the properties involved in this application. Staff supports this request.
 - C. **Section 146-11.C – Proposed Layout Plan** – The plan is required to first floor elevations, all existing utilities and all existing improvements proposed to remain and be removed.

- D. **Section 146-11.D – Grading Plan** – The applicant is required to submit a grading plan, however no changes to the existing topography are proposed with this application.
- E. **Section 146-11.L – Architectural Plan** – An architectural plan is required to be submitted with a subdivision plan, however this application is for the relocation of an existing lot line and no construction is proposed with this application.
- F. **Section 146-24.D – Road Way Improvements** – Increase the width of the right-of-way to in a minimum of 50 feet. This applies to both Kimball Avenue and Smith Avenue.
- G. **Section 146.27 – Installation of Sidewalks** – The applicant has requested a waiver to eliminate the need to install sidewalks along the frontage of Kimball Avenue.
- H. **Section 146-38 – Street Lighting** - The applicant has requested a waiver to eliminate the requirement for the installation of street lighting along the frontages of this project.

If there are any questions pertaining to the comments listed above, I would ask that you contact the reviewing department directly or I can be reached at 267-536-1017.

Sincerely,

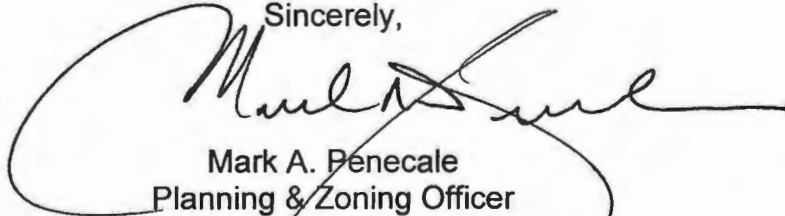

Mark A. Penecale
Planning & Zoning Officer

Cc: James Sheridan; Developer – US Mail & Email
Timothy P. Woodrow, PE.; Project Engineer – US Mail & Email
Lawrence T. Matteo, Jr.; Director of Planning & Code Enforcement
Michael E. Powers; Abington Township Engineer
Bruce Hentschel; Abington Township Building Inspector
Ken Clark; Abington Township Fire Marshal
File Copy (2)

**MONTGOMERY COUNTY
BOARD OF COMMISSIONERS**

JOSH SHAPIRO, CHAIR

LESLIE S. RICHARDS, VICE CHAIR

BRUCE L. CASTOR, JR., COMMISSIONER



**MONTGOMERY COUNTY
PLANNING COMMISSION**

MONTGOMERY COUNTY COURTHOUSE • PO BOX 311
NORRISTOWN, PA 19404-0311
610-278-3722

FAX: 610-278-3941 • TDD: 610-631-1211
WWW.MONTCOPA.ORG

JODY L. HOLTON, AICP
EXECUTIVE DIRECTOR

January 15, 2015

Mr. Mark A. Penecale, Zoning Officer
Abington Township
1176 Old York Road
Abington, Pennsylvania 19001-3713

Re: MCPC #14-0259-001
Plan Name: 1777 Kimbell Avenue

(3 lots comprising 0.86 acres)
Situates: Kimbell Avenue (East)
South of Windsor Avenue
Abington Township

Applicant's Name and Address

James Sheridan
55 Lynn Avenue
Oreland, PA 19075

Contact Information

R. Jordan, Woodrow & Associates
Phone: 215-542-5648
rjordan@woodrowinc.com

Dear Mr. Penecale:

We have reviewed the above referenced Minor Subdivision Plan in accordance with Section 502 of Act 247, "The Municipalities Planning Code," as you requested on November 28, 2014. We forward this letter as a report of our review and recommendations.

Applicant's Proposal

The applicant proposes to subdivide one 0.86 acre property into three lots. The new lots would be 22,641 s.f., 7,662 s.f., and 7,662 s.f., respectively. The property is the site of an existing dwelling and shed, the latter of which is proposed for removal. There is also a well on-site. The property lies in the R4 High Density Residential District. The applicant proposes public water and sewer. The applicant has submitted a Final Plan; it is dated October 24, 2014.

Review Comments

- A. Well – The application says that public water will be used. What is the status of the existing well?
- B. Swale – We recommend that the swale be vegetated (see the attached literature on vegetated drainage swales).
- C. Easement – What is the purpose of the stormwater management easement?

D. Plan Information [§146-11] –

1. Approximate acreage of lots surrounding the site shall be shown.
2. Contour lines are provided; annotation of the lines with elevations would be helpful (some are annotated, but not on the site).

Recommendation

We recommend approval of this subdivision provided the proposed plan complies with your municipal land use regulations and all other appropriate regulations.

Please note that the review comments and recommendations contained in this report are advisory to the municipality and final disposition for the approval of any proposal will be made by the municipality.

Should the governing body approve a final plat of this proposal, the applicant must present the plan to our office for seal and signature prior to recording with the Recorder of Deeds office. A paper copy bearing the municipal seal and signature of approval must be supplied for our files.

Sincerely,

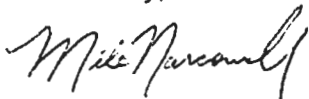

Mike Narcowich, AICP, Principal Community Planner
610.278.5238 - mnarcowi@montcopa.org

- c: Michael LeFevre, Township Manager
Timothy P. Woodrow, R.P.E., Woodrow & Associates, Inc.; Applicant's Engineer
Lawrence T. Matteo Jr., Director of Planning and Code Enforcement
Michael E. Powers, P.E., Township Engineer
Michael P. Clarke, Esq., Rudolph Clarke, LLC, Township Solicitor

Attachments: Copy of Plan; "Planning by Design: Enhancing Stormwater Management" by MCPC



**Township of Abington
APPLICATION FOR APPROVAL OF PLAN**

Submission Date 11/26/14 Application No. SD-15-01

To the Board of Commissioners of the Township of Abington:

The undersigned hereby makes application for approval of plan type as indicated below, under the provisions of the Code of Abington Township, Chapter 146, entitled 'The Subdivision and Land Development Regulations of the Township of Abington of 1991', and any supplements and amendments thereto.

Signature of Applicant

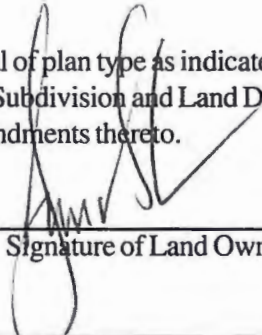

Signature of Land Owner

Title of Plan Submitted: 1777 Kimball Avenue

A. Plan Type:

- | | |
|---|---|
| <input type="checkbox"/> Minor Subdivision | <input type="checkbox"/> Minor Land Development |
| <input type="checkbox"/> Preliminary Major Subdivision | <input type="checkbox"/> Pre Major Land Development |
| <input type="checkbox"/> Final Major Subdivision | <input type="checkbox"/> Final Major Land Development |
| <input checked="" type="checkbox"/> Preliminary Major SD & LD | <input type="checkbox"/> Final Major SD & LD |

B. Plan Identification:

Plan Dated: June 16, 2014 Engineer: Woodrow & Associates, C/o Robert Jordan

Plan Proposes: Brief narrative of the proposed activity. Commercial applications to include building square footage and specific uses; Residential applicants to include number of lots and amount of dwelling unit types:

Creation of a three (3) lot subdivision

C. Property Identification:

Address/Location 1777 Kimball Avenue, Abington Township

between streets Old Welsh Road and Windsor Avenue

(continued on next page)

**Township of Abington
APPLICATION FOR MODIFICATION OF PLAN**

Submission Date 11/26/14 Application No. SD-15-01

To the Board of Commissioners of the Township of Abington:

The undersigned hereby makes application for modification of plan application requirements as indicated below, under the provisions of the Code of Abington Township, Chapter 146, entitled 'The Subdivision and Land Development Regulations of the Township of Abington of 1991', and any supplements and amendments thereto.

Signature of Applicant

Signature of Land Owner

Title of Plan Submitted: 1777 Kimball Avenue

A. Plan Type:

- Minor Subdivision
- Preliminary Major Subdivision
- Final Major Subdivision
- Preliminary Major SD & LD

- Minor Land Development
- Pre Major Land Development
- Final Major Land Development
- Final Major SD & LD

<u>Regulation Topic</u>	<u>Section #</u>	<u>Extent of Modification Requested</u>
Road Improvement	146-24.D.(1)	Road improvement, Kimball Avenue
Sidewalk	146-27.A	Sidewalk along Kimball Avenue
Street Lighting	146-38	Street lights

.....
Fees acknowledged and modification request received:

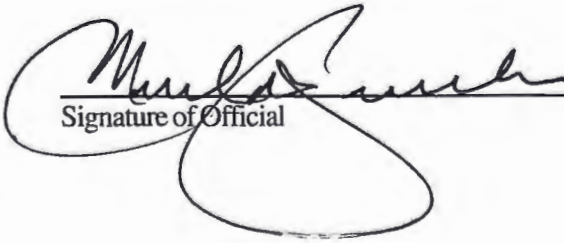
Signature of Official

11/26/14
Date

D. Applicant Identification:

Applicant James Sheridan
 Address 55 Lynn Avenue, Oreland, PA 19075 Phone 215-517-5577

Land Owner John J. and Irene F. Turzer Trust
 Address 1777 Kimball Avenue, Willow Grove, PA 19090 Phone _____

Equitable Land Owner John J. and Irene F. Turzer Trust
 Address 1777 Kimball Avenue, Willow Grove, PA 19090 Phone _____

Architect _____
 Address _____ Phone _____

Engineer Woodrow & Associates, c/o Robert Jordan
 Address 1108 N. Bethlehem Pike, Suite 5, Lower Wynedd PA, 19002 Phone 215-542-5648

Attorney Joseph C. Kuhls, Esq.
 Address 500 Office Center Drive, Suite 400, Ft. Washington, PA 19034 Phone 215-277-5536

IMPROVEMENTS PROPOSED UNITS ESTIMATED COST

Streets	<u>N/A</u>		
Street Widening	<u>N/A</u>		
Street Signs	<u>N/A</u>		
Street Lighting	<u>N/A</u>		
Curbs	<u>N/A</u>		
Sidewalks	<u>N/A</u>		
Storm Sewers	<u>15" ADS</u>	<u>297 LF</u>	<u>\$12,000.00</u>
Water Supply	<u>N/A</u>		
Fire Hydrants	<u>N/A</u>		
Sanitary Sewers	<u>N/A</u>		
Monuments	<u>Concrete Monument</u>	<u>5</u>	<u>\$ 1,750.00</u>
Shade Trees	<u>Street Trees</u>	<u>2</u>	<u>\$ 600.00</u>
Open Space	<u>N/A</u>		
Park Lane	<u>N/A</u>		
Other	<u>Inlets</u>	<u>4</u>	<u>\$ 4,800.00</u>
	<u>Landscaping</u>	<u>L.S.</u>	<u>\$ 5,000.00</u>
Total Cost:			<u>\$ 24,150.00</u>

Fees received from applicant:

Check #2306 Rec # 900069
 Check #2307 Rec # 900070

Application Fee _____ \$500.00
 Review Escrow _____ \$ 2,000.00
 Total _____

Fees acknowledged and application accepted as complete:

Maria L. ...
 Signature of Official

Date

RECEIVED
 NOV 26 2014

BY: MAX

APPLICATION NO. 14-08

Opinion and Order of the Board

The application of **Irene Turzer and James Sheridan** applicants for the property located at 1777 Kimball Avenue, Willow Grove, PA. The applicants filed an appeal to the actions of the Zoning Officer relating to the interpretation of Section 801.R of the Zoning Ordinance. In the alternative, the applicants have requested a variance from Section 801.R of the Zoning Ordinance of the Township of Abington. The property is served by an on-site well for water supply. The applicant seeks approval to reduce the size of the property from .87 of an acre to .52 of an acre. Abington Township requires a minimum of 1 area for all on-site wells.

The property is zoned in the (R-4) Residential District in Ward No. 8 of the Township of Abington.

Upon due advertisement, a public hearing was held in the Abington Township Building, 1176 Old York Road, Abington, Pennsylvania, on Tuesday, June 17, 2014, commencing at 7:10 PM.

Present at the hearing were:

Barbara M. Wertheimer, Esq. Chairperson
John DiPrimio, Vice Chair
Edward A. Mebus, Member
Linda Kates, Member
Michael O'Connor, Member

Bruce J. Eckel, Esq., Board Solicitor
Rex R. Herder, Jr., Esq. for the Protestants
Mark Penecale, Planning & Zoning Officer
Shaun Littlefield, Zoning Inspector

Findings of Fact

1. The name and address of the owner is Irene Turzer, 1777 Kimball Avenue, Willow Grove, PA 19090.
2. The name and address of the applicants are Irene Turzer, 1777 Kimball Avenue, Willow Grove, Pa 19090; and James Sheridan, 55 Lynn Avenue, Oreland, PA, 19075.
3. The applicants were represented by Joseph C. Kuhls, 500 Office Center Drive, Suite 400, Fort Washington, PA 19034.
4. The property involved in this application is located at 1777 Kimball Avenue, Willow Grove, PA 19090.
5. The following exhibits were submitted at the hearing:

- B-1 Proof of Publication
- B-2 Certification of Posting

- A-1 Formal Application
- A-2 Sketch Plan No. 2, for 1777 Kimball Avenue by Timothy P. Woodrow
- A-3 Section 801.R of the Ordinance
- A-4 Section 304.3 of the Abington Township Ordinance
- A-5 2010 Order the Zoning Hearing Board
- A-6 Section of the Pennsylvania Municipalities Planning Code regarding ambiguity.

6. Applicant Irene Turzer owns a .96 acre property (the "Subject Property") improved with and used as a single-family dwelling (the "Existing Home"). The Existing Home is served by a private well.
7. Public water service exists within five hundred (500) feet of the Subject Property.
8. The Subject Property is within Abington Township's Residential High Density (R-4) Zoning District which permits a minimum lot area of 7,500 square feet (.172 acre)
9. For purposes of establishing a minimum lot area in the R-4 District, no distinction is made between lots served by public water versus those served by wells. See Abington Township Zoning Ordinance (the "Ordinance") Section 304.3.
10. The Ordinance Sections 304.2 and 301.2 further permits a building, and lot, to be used as a Single-Family Detached (H-8) dwelling.
11. Accordingly, the Subject Property is put to a conforming use, upon a dimensionally conforming lot. Neither non-conforming use, nor dimensional nonconformity exists.
12. Applicants Turzer and Sheridan (equitable owner) desire to subdivide the Subject Property into three lots ("Lot 1"; "Lot 2"; and "Lot 3"), pursuant to a "Subdivision Plan" prepared by Woodrow & Associates, Engineers. Exhibit A-2.

13. The Existing Home will remain on Lot 1. Ms. Turzer will retain Lot 1 and continue to reside in the Existing Home.
14. Lot 1 will contain an area of .52 acre; Lot 2 will contain an area of .172 acre; and Lot 3 will contain an area of .179 acre. Accordingly, each of the three lots resulting from the subdivision of the Subject Property will satisfy the minimum lot area requirements of the R-4 District in which the Subject Property is located.
15. Abington Township Zoning Ordinance Section 801.R mandates that "Where no public water service is available within five hundred (500) feet of a site undergoing subdivision or land development, the [] applicant may, upon approval of the Board of Commissioners, be permitted **to construct** a well on each lot, provided standards herein have been satisfied."
16. One of the standards enumerated in Ordinance Section 801.R for **proposed new well construction** (emphasis added) by a subdivider of property within five hundred (500) feet of public water service, is a minimum lot area of one acre.
17. Given the fact that public water is available within 500 feet of the Subject Property, and given the fact that each of the three new lots (Lot 1, Lot 2 and Lot 3) are less than one-acre in area, although in conformance with the minimum lot area requirements of the R-4 District, Ordinance Section 801 R prohibits construction of any new well on any of the lots.
18. Accordingly, the Applicants, in conformance with Ordinance requirements, do not propose the construction of any new wells on any portion of the Subject Property. The Existing Dwelling on Lot 1 will be served by the existing well located thereon, while Lot

2 and Lot 3 will be served by new public water connections in conformance with Ordinance Section 801.R.

19. Lot 2 and lot 3 will be served by public water and no well will be constructed on either lot.

20. Since the Applicants are not requesting that a well be constructed, Section 801.R of the Ordinance is not applicable to this application.

21. During discussions with Township staff regarding the proposed Subdivision Plan for the Subject Property, the Zoning Officer rendered his interpretation that the .98 acre Subject Property currently served by well water as it exists today, somehow fails to conform with the Ordinance Section 801.R requirement that properties undergoing subdivision may only **construct** new wells upon parcels of at least one acre.

22. The Zoning Officer views the alleged non-conformity as a "grandfathered" or "legal" non-conformity (hence the absence of any pending Notice of Violation), but opines that the currently proposed *further* subdivision of the allegedly legally non-conforming Subject Property would then violate the Ordinance 1110.L(1) mandate that "no non-conforming lot shall be reduced in size".

23. That determination by the Zoning Officer gives rise to the Applicant's application (the "Application") to the Abington Township Zoning Hearing Board (the "Board"). The only portion of the Subject Property subject to the Application is the proposed .52 acre Lot 1, containing the Existing Home to be retained by Turzer, served by the existing well.

24. A hearing (the "Hearing") on the Application was held before the Board on June 17, 2014. Owners of real property in the vicinity of the Subject Property (the "Protestants") entered their appearance at the Hearing through counsel, in opposition to the Application.

25. R. Rex Herder, Esquire, from Eastburn and Gray represented the objecting neighbors.
26. The Board is now called upon, primarily, to review the Zoning Officer's opinion, and determine for itself if the Subject Property as it currently exists fails to conform to Ordinance Section 801.R; and/or if the Subdivision Plan violates Ordinance Section 801.R. That review of the Zoning Officer's opinion is at the core of the Application.
27. The Application to this Board also, in the alternative, requested a variance from the imposition of Ordinance Section 801.R requirements.
28. Since the Board upholds the appeal from the Zoning Officer's decision, and determines that Section 801.R is inapplicable to this application, that variance request will not be addressed. The variance relief was only ever requested in the alternative, in the event the Zoning Officer's opinion was upheld.
29. Since the Applicants are not requesting that a well be constructed, Section 801.R of the Ordinance is not applicable to this application.
30. The requirements of Ordinance Section 801.R apply only to subdivisions proposing new wells.
31. Even if that language is found to be somehow ambiguous, the Pennsylvania Municipalities Planning Code (the "MPC") requires that any perceived ambiguity must be resolved against the one acre lot area restriction, and in favor of the Applicant. Accordingly, even if Ordinance Section 801.R is found to be at all ambiguous, the Zoning Officer's interpretation must still be overruled. See MPC Section 603.1
32. The Zoning Officer's interpretation that the Subject Property and its subdivision is somehow violative of Ordinance 801.R, is erroneous and must be over-ruled by the Board.

Conclusions of Law

1. The Subject Property is not a non-conforming lot.
2. The subdivision of the Subject Property as depicted on the Plan, and the resulting decreased size of Lot 1 thereof, does not violate Ordinance Section 801.R.
3. Decreasing the size of the Subject Property parcel containing the Existing Home and well from its current .98 acre area to the .52 acre area of Lot 1 (still in excess of the .172 minimum lot area applicable in the R-4 District) does not violate any provision of the Ordinance.
4. The determination of the Zoning Officer that the proposed subdivision of the Subject Property as depicted on the Subdivision Plan violates Ordinance Section 801.R, must be overruled.
5. The Application appealing the actions of the Zoning Officer must be granted.

Opinion and Order of the Board

The Board sustains the appeal of the action of the zoning officer. Therefore, this application is **APPROVED.**

Zoning Hearing Board of the Township of Abington

Barbara M. Wertheimer, Esq, Chairperson

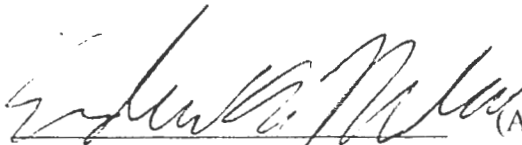
Edward A. Mebus, Member (Aye)

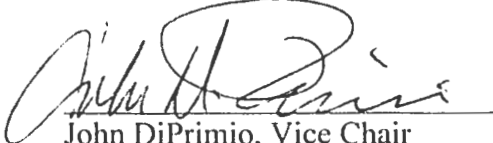
John DiPrimio, Vice Chair (Nay)

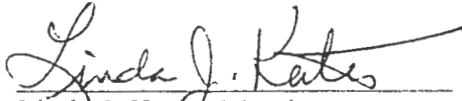
Linda J. Kates, Member (Aye)

Michael O'Connor, Member (Aye)

This decision is passed 3-2.

Decision Date
August 19, 2014

Note: *There is a 30-day period after the date of a decision for an aggrieved person to file an appeal in court to contest a denial by the Zoning Hearing Board.*

Applicants that take action on a Zoning Hearing Board approval during the 30-day appeal period do so at their own risk.

All applicable permits must be secured from the Township of Abington within (6) six months of this decision or this decision becomes null and void.

Mark Penecale

From: Kuhls Law <jckuhls@kuhlslaw.com>
Sent: Monday, January 26, 2015 11:18 AM
To: Mark Penecale
Cc: Larry Matteo; jckuhls@kuhlslaw.com
Subject: Waiver Letter; 1777 Kimball Avenue

Mr. Penecale,

As you know, this firm represents James Sheridan in his pending subdivision/land development application relative to 1777 Kimball Avenue. Please accept this letter as a waiver of any and all time limitations set forth in the Pennsylvania Municipalities Planning Code, or elsewhere, for consideration and/or action on the pending application. If you have any questions, please let me know.

Sincerely,

Joseph C. Kuhls, Esq.

KUHLS LAW PLLC

500 Office Center Drive, Suite 400
Fort Washington PA 19034
215.277.5536

This message is intended only for use by recipient and may contain information which is attorney-client privileged, confidential, and exempt from disclosure under applicable law. If the reader is not the intended recipient, or agent thereof, know that any dissemination, distribution or copying of this message is prohibited. If you have received this communication in error, please immediately notify the sender at 215.277.5536 or by email.

Mr. & Mrs. J Solheim
or current resident
1756 Kimball Ave
Willow Grove Pa 19090-3808

Leslie Gakoumis
or current resident
1768 Kimball Ave
Willow Grove Pa 19090-3808

Mr. & Mrs. J Morris
or current resident
1802 Kimball Ave
Willow Grove Pa 19090-3810

Robert Engart
or current resident
1806 Kimball Ave
Willow Grove Pa 19090-3810

Mr. & Mrs. J Pietrzak
or current resident
1812 Kimball Ave
Willow Grove Pa 19090-3810

Mr. & Mrs. S Edmonds
or current resident
1820 Kimball Ave
Willow Grove Pa 19090-3810

Mr. & Mrs. S Messina
or current resident
1751 Kimball Ave
Willow Grove Pa 19090-3807

Mr. & Mrs. J Schrader
or current resident
1755 Kimball Ave
Willow Grove Pa 19090-3807

Mr. & Mrs. T Lombardi
or current resident
1759 Kimball Ave
Willow Grove Pa 19090-3807

Mr. & Mrs. J Turzer
or current resident
1777 Kimball Ave
Willow Grove Pa 19090-3807

Joan Kushenerock
or current resident
1783 Kimball Ave
Willow Grove Pa 19090-3807

Mr. & Mrs. N Panaccio
or current resident
2944 Windsor Ave
Willow Grove Pa 19090-3833

Erika Wines
or current resident
2940 Windsor Ave
Willow Grove Pa 19090-

Mary Morel
or current resident
1807 Kimball Ave
Willow Grove Pa 19090-3809

Donna Meleco
or current resident
20 Pheasant Run
Horsham Pa 19044-1823

Andrew Dantonio
or current resident
1815 Kimball Ave
Willow Grove Pa 19090-3809

Mr. & Mrs. J Welte
or current resident
1819 Kimball Ave
Willow Grove Pa 19090-3809

Carol Newman
or current resident
1761 Smith Ave
Willow Grove Pa 19090-3814

Mr. & Mrs. J Mcguigan
or current resident
1767 Smith Ave
Willow Grove Pa 19090-3814

Mr. & Mrs. C Whittall
or current resident
1771 Smith Ave
Willow Grove Pa 19090-3814

Mr. & Mrs. W Gebhardt
or current resident
551 Hawthorne Ln
Harleysville Pa 19438-2169

Mr. & Mrs. C Moritz
or current resident
2925 Windsor Ave
Willow Grove Pa 19090-3826

Ann Camacho
or current resident
2929 Windsor Ave
Willow Grove Pa 19090-3826

Mr. & Mrs. S Newman
or current resident
2933 Windsor Ave
Willow Grove Pa 19090-3826

Family Bermel
or current resident
2937 Windsor Ave
Willow Grove Pa 19090-3826

Mr. & Mrs. G Spolansky
or current resident
2941 Windsor Ave
Willow Grove Pa 19090-3826

Mr. & Mrs. J Geoghan
or current resident
2945 Windsor Ave
Willow Grove Pa 19090-3826

Mr. & Mrs. L Capili
or current resident
2949 Windsor Ave
Willow Grove Pa 19090-3826

Mr. & Mrs. G Aspen
or current resident
2953 Windsor Ave
Willow Grove Pa 19090-3826

Mr. & Mrs. V Nouv
or current resident
2957 Windsor Ave
Willow Grove Pa 19090-3826

STAPLES

Etiquette de format 25 mm x 67 mm compatible avec Avery® 5160/8160
Label size 2 5/8" x 2 3/4" compatible with Avery® 5160/8160

Mr. & Mrs. L Jones
or current resident
2963 Windsor Ave
Willow Grove Pa 19090-3826

Mr. & Mrs. L Dalessio
or current resident
2920 Windsor Ave
Willow Grove Pa 19090-3827

Mr. & Mrs. J Frentzen
or current resident
2924 Windsor Ave
Willow Grove Pa 19090-3827

Glen Schaeffer
or current resident
2930 Windsor Ave
Willow Grove Pa 19090-3833

Mr. & Mrs. S Cole
or current resident
2934 Windsor Ave
Willow Grove Pa 19090-3833



Label size 4 1/2" x 6 1/2" compatible with Avery® 5160/8160

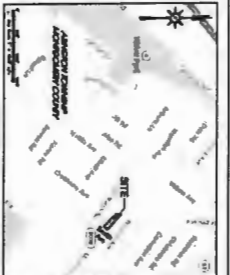

LOCATION MAP

GENERAL PLANNING NOTES

1. THE GENERAL PLAN IS SUBJECT TO THE APPROVAL OF THE CITY ENGINEER AND THE STATE DEPARTMENT OF TRANSPORTATION.
2. THE GENERAL PLAN IS SUBJECT TO THE APPROVAL OF THE CITY ENGINEER AND THE STATE DEPARTMENT OF TRANSPORTATION.
3. THE GENERAL PLAN IS SUBJECT TO THE APPROVAL OF THE CITY ENGINEER AND THE STATE DEPARTMENT OF TRANSPORTATION.
4. THE GENERAL PLAN IS SUBJECT TO THE APPROVAL OF THE CITY ENGINEER AND THE STATE DEPARTMENT OF TRANSPORTATION.
5. THE GENERAL PLAN IS SUBJECT TO THE APPROVAL OF THE CITY ENGINEER AND THE STATE DEPARTMENT OF TRANSPORTATION.
6. THE GENERAL PLAN IS SUBJECT TO THE APPROVAL OF THE CITY ENGINEER AND THE STATE DEPARTMENT OF TRANSPORTATION.
7. THE GENERAL PLAN IS SUBJECT TO THE APPROVAL OF THE CITY ENGINEER AND THE STATE DEPARTMENT OF TRANSPORTATION.
8. THE GENERAL PLAN IS SUBJECT TO THE APPROVAL OF THE CITY ENGINEER AND THE STATE DEPARTMENT OF TRANSPORTATION.
9. THE GENERAL PLAN IS SUBJECT TO THE APPROVAL OF THE CITY ENGINEER AND THE STATE DEPARTMENT OF TRANSPORTATION.
10. THE GENERAL PLAN IS SUBJECT TO THE APPROVAL OF THE CITY ENGINEER AND THE STATE DEPARTMENT OF TRANSPORTATION.

PLANNING LEGEND

Proposed Street	Existing Street
Proposed Sidewalk	Existing Sidewalk
Proposed Planting	Existing Planting
Proposed Utility	Existing Utility
Proposed Structure	Existing Structure
Proposed Fencing	Existing Fencing
Proposed Signage	Existing Signage
Proposed Lighting	Existing Lighting
Proposed Storm Drain	Existing Storm Drain
Proposed Sewer	Existing Sewer
Proposed Water	Existing Water
Proposed Gas	Existing Gas
Proposed Electric	Existing Electric
Proposed Telephone	Existing Telephone
Proposed Cable	Existing Cable
Proposed Other	Existing Other

PROJECT SUMMARY DATA

Project Name	1777 Kimball Avenue
Site Area	1.25 Acres
Lot Area	1.25 Acres
Number of Lots	1
Number of Units	1
Number of Stories	1
Number of Parking Spaces	1
Number of Driveways	1
Number of Entrances	1
Number of Exits	1
Number of Entrances	1
Number of Exits	1

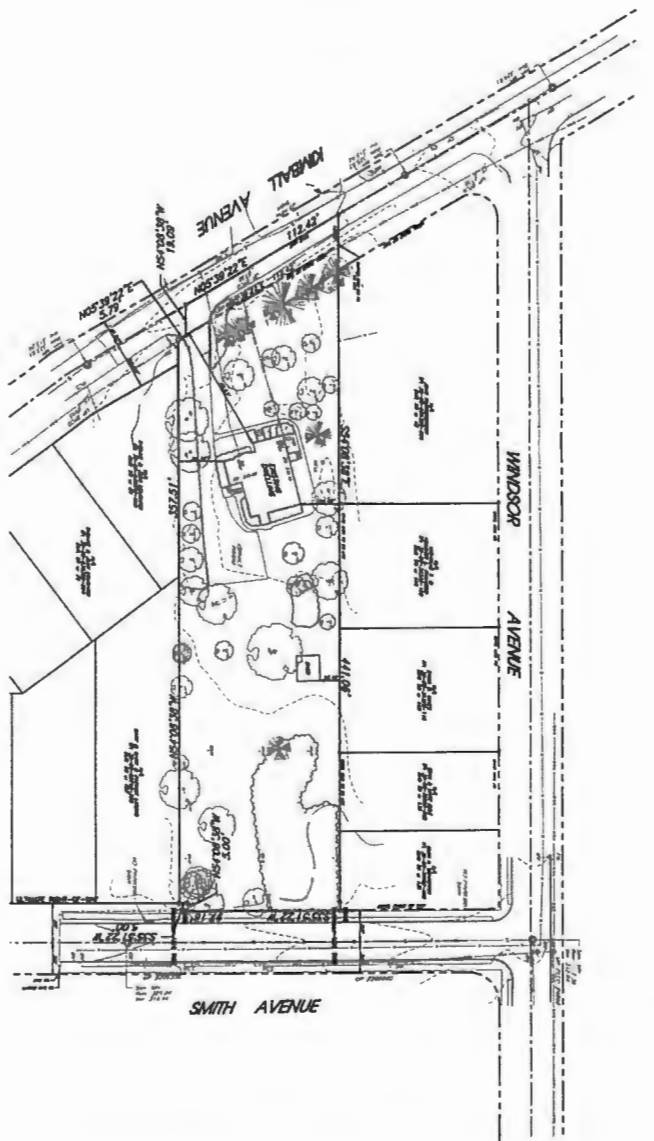

<p>WOODROW & ASSOCIATES, INC. LANDSCAPE ARCHITECTS</p>	<p>EXISTING FEATURES PLAN 1777 KIMBALL AVENUE</p>	<p>DATE: 11/15/2011 SCALE: 1/8" = 1'-0"</p>	<p>PROJECT NO.: 1111111111 DRAWING NO.: 1111111111</p>	<p>DESIGNED BY: J. WOODROW CHECKED BY: M. WOODROW</p>	<p>APPROVED BY: J. WOODROW</p>	<p>PROJECT LOCATION: 1777 KIMBALL AVENUE, WASHINGTON, DC</p>
	<p>DATE: 11/15/2011 SCALE: 1/8" = 1'-0"</p>	<p>PROJECT NO.: 1111111111 DRAWING NO.: 1111111111</p>	<p>DESIGNED BY: J. WOODROW CHECKED BY: M. WOODROW</p>	<p>APPROVED BY: J. WOODROW</p>	<p>PROJECT LOCATION: 1777 KIMBALL AVENUE, WASHINGTON, DC</p>	

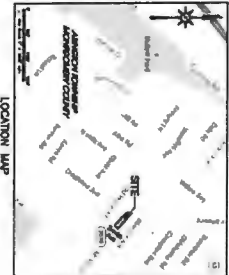
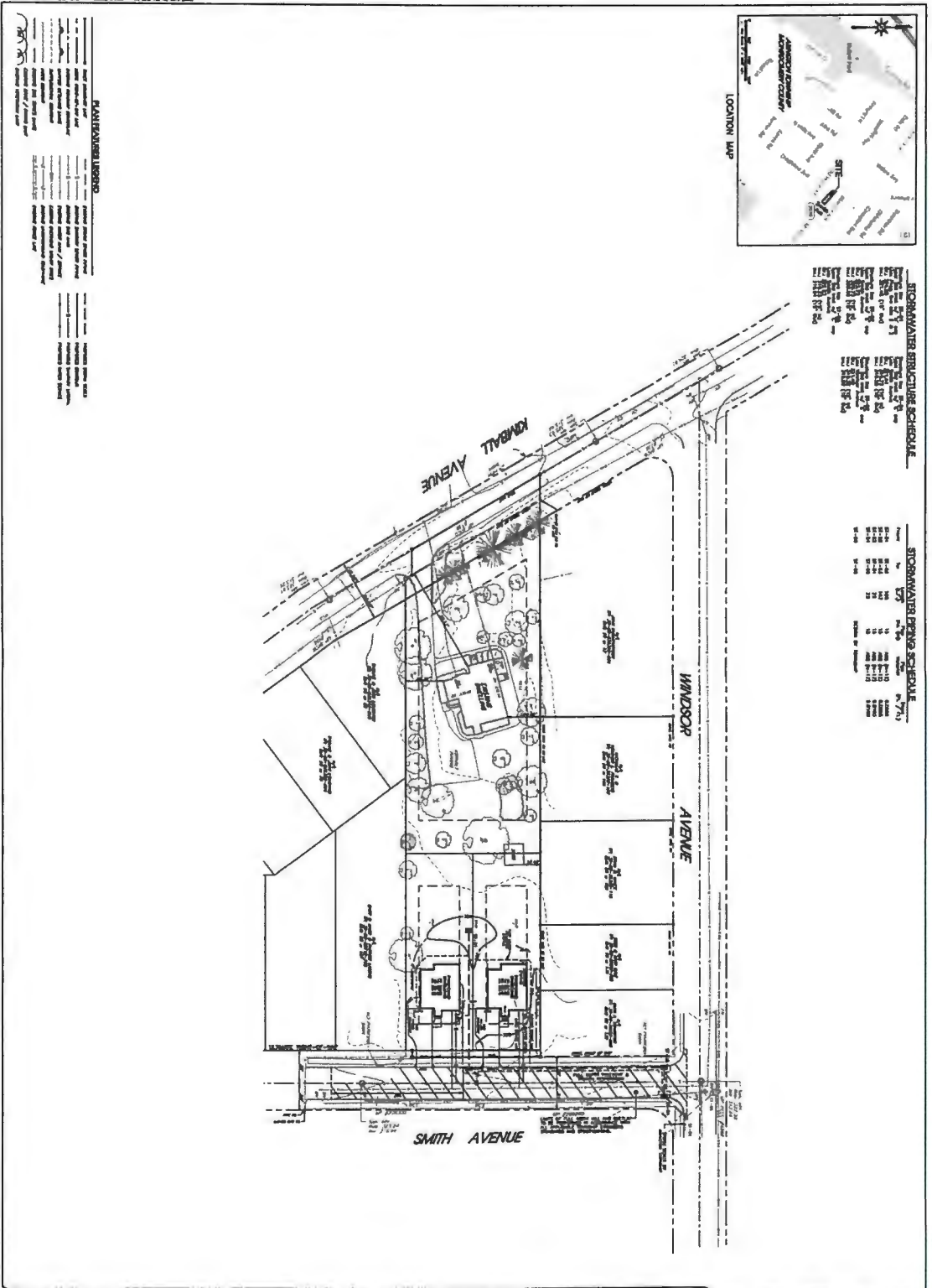

STORMWATER STRUCTURE SCHEDULE

Item	Quantity	Notes
1. 12" x 12" x 12" Catchment Basin	1	See Detail 101
2. 18" x 18" x 18" Catchment Basin	1	See Detail 102
3. 24" x 24" x 24" Catchment Basin	1	See Detail 103
4. 30" x 30" x 30" Catchment Basin	1	See Detail 104
5. 36" x 36" x 36" Catchment Basin	1	See Detail 105
6. 42" x 42" x 42" Catchment Basin	1	See Detail 106
7. 48" x 48" x 48" Catchment Basin	1	See Detail 107
8. 54" x 54" x 54" Catchment Basin	1	See Detail 108
9. 60" x 60" x 60" Catchment Basin	1	See Detail 109
10. 66" x 66" x 66" Catchment Basin	1	See Detail 110
11. 72" x 72" x 72" Catchment Basin	1	See Detail 111
12. 78" x 78" x 78" Catchment Basin	1	See Detail 112
13. 84" x 84" x 84" Catchment Basin	1	See Detail 113
14. 90" x 90" x 90" Catchment Basin	1	See Detail 114
15. 96" x 96" x 96" Catchment Basin	1	See Detail 115
16. 102" x 102" x 102" Catchment Basin	1	See Detail 116
17. 108" x 108" x 108" Catchment Basin	1	See Detail 117
18. 114" x 114" x 114" Catchment Basin	1	See Detail 118
19. 120" x 120" x 120" Catchment Basin	1	See Detail 119
20. 126" x 126" x 126" Catchment Basin	1	See Detail 120
21. 132" x 132" x 132" Catchment Basin	1	See Detail 121
22. 138" x 138" x 138" Catchment Basin	1	See Detail 122
23. 144" x 144" x 144" Catchment Basin	1	See Detail 123
24. 150" x 150" x 150" Catchment Basin	1	See Detail 124
25. 156" x 156" x 156" Catchment Basin	1	See Detail 125
26. 162" x 162" x 162" Catchment Basin	1	See Detail 126
27. 168" x 168" x 168" Catchment Basin	1	See Detail 127
28. 174" x 174" x 174" Catchment Basin	1	See Detail 128
29. 180" x 180" x 180" Catchment Basin	1	See Detail 129
30. 186" x 186" x 186" Catchment Basin	1	See Detail 130
31. 192" x 192" x 192" Catchment Basin	1	See Detail 131
32. 198" x 198" x 198" Catchment Basin	1	See Detail 132
33. 204" x 204" x 204" Catchment Basin	1	See Detail 133
34. 210" x 210" x 210" Catchment Basin	1	See Detail 134
35. 216" x 216" x 216" Catchment Basin	1	See Detail 135
36. 222" x 222" x 222" Catchment Basin	1	See Detail 136
37. 228" x 228" x 228" Catchment Basin	1	See Detail 137
38. 234" x 234" x 234" Catchment Basin	1	See Detail 138
39. 240" x 240" x 240" Catchment Basin	1	See Detail 139
40. 246" x 246" x 246" Catchment Basin	1	See Detail 140
41. 252" x 252" x 252" Catchment Basin	1	See Detail 141
42. 258" x 258" x 258" Catchment Basin	1	See Detail 142
43. 264" x 264" x 264" Catchment Basin	1	See Detail 143
44. 270" x 270" x 270" Catchment Basin	1	See Detail 144
45. 276" x 276" x 276" Catchment Basin	1	See Detail 145
46. 282" x 282" x 282" Catchment Basin	1	See Detail 146
47. 288" x 288" x 288" Catchment Basin	1	See Detail 147
48. 294" x 294" x 294" Catchment Basin	1	See Detail 148
49. 300" x 300" x 300" Catchment Basin	1	See Detail 149
50. 306" x 306" x 306" Catchment Basin	1	See Detail 150
51. 312" x 312" x 312" Catchment Basin	1	See Detail 151
52. 318" x 318" x 318" Catchment Basin	1	See Detail 152
53. 324" x 324" x 324" Catchment Basin	1	See Detail 153
54. 330" x 330" x 330" Catchment Basin	1	See Detail 154
55. 336" x 336" x 336" Catchment Basin	1	See Detail 155
56. 342" x 342" x 342" Catchment Basin	1	See Detail 156
57. 348" x 348" x 348" Catchment Basin	1	See Detail 157
58. 354" x 354" x 354" Catchment Basin	1	See Detail 158
59. 360" x 360" x 360" Catchment Basin	1	See Detail 159
60. 366" x 366" x 366" Catchment Basin	1	See Detail 160
61. 372" x 372" x 372" Catchment Basin	1	See Detail 161
62. 378" x 378" x 378" Catchment Basin	1	See Detail 162
63. 384" x 384" x 384" Catchment Basin	1	See Detail 163
64. 390" x 390" x 390" Catchment Basin	1	See Detail 164
65. 396" x 396" x 396" Catchment Basin	1	See Detail 165
66. 402" x 402" x 402" Catchment Basin	1	See Detail 166
67. 408" x 408" x 408" Catchment Basin	1	See Detail 167
68. 414" x 414" x 414" Catchment Basin	1	See Detail 168
69. 420" x 420" x 420" Catchment Basin	1	See Detail 169
70. 426" x 426" x 426" Catchment Basin	1	See Detail 170
71. 432" x 432" x 432" Catchment Basin	1	See Detail 171
72. 438" x 438" x 438" Catchment Basin	1	See Detail 172
73. 444" x 444" x 444" Catchment Basin	1	See Detail 173
74. 450" x 450" x 450" Catchment Basin	1	See Detail 174
75. 456" x 456" x 456" Catchment Basin	1	See Detail 175
76. 462" x 462" x 462" Catchment Basin	1	See Detail 176
77. 468" x 468" x 468" Catchment Basin	1	See Detail 177
78. 474" x 474" x 474" Catchment Basin	1	See Detail 178
79. 480" x 480" x 480" Catchment Basin	1	See Detail 179
80. 486" x 486" x 486" Catchment Basin	1	See Detail 180
81. 492" x 492" x 492" Catchment Basin	1	See Detail 181
82. 498" x 498" x 498" Catchment Basin	1	See Detail 182
83. 504" x 504" x 504" Catchment Basin	1	See Detail 183
84. 510" x 510" x 510" Catchment Basin	1	See Detail 184
85. 516" x 516" x 516" Catchment Basin	1	See Detail 185
86. 522" x 522" x 522" Catchment Basin	1	See Detail 186
87. 528" x 528" x 528" Catchment Basin	1	See Detail 187
88. 534" x 534" x 534" Catchment Basin	1	See Detail 188
89. 540" x 540" x 540" Catchment Basin	1	See Detail 189
90. 546" x 546" x 546" Catchment Basin	1	See Detail 190
91. 552" x 552" x 552" Catchment Basin	1	See Detail 191
92. 558" x 558" x 558" Catchment Basin	1	See Detail 192
93. 564" x 564" x 564" Catchment Basin	1	See Detail 193
94. 570" x 570" x 570" Catchment Basin	1	See Detail 194
95. 576" x 576" x 576" Catchment Basin	1	See Detail 195
96. 582" x 582" x 582" Catchment Basin	1	See Detail 196
97. 588" x 588" x 588" Catchment Basin	1	See Detail 197
98. 594" x 594" x 594" Catchment Basin	1	See Detail 198
99. 600" x 600" x 600" Catchment Basin	1	See Detail 199
100. 606" x 606" x 606" Catchment Basin	1	See Detail 200

<p>WOODROW & ASSOCIATES, INC. 1777 KIMBALL AVENUE WASHINGTON, DC 20004 (202) 556-1100 FAX (202) 556-1101 WWW.WOODROW-ASSOCIATES.COM</p>	<p>PROJECT NO. 1777 KIMBALL AVENUE</p>	<p>DATE 11/11/11</p>	<p>SCALE 1" = 10'</p>	<p>PROJECT NAME 1777 KIMBALL AVENUE</p>	<p>CLIENT 1777 KIMBALL AVENUE</p>
	<p>DESIGNER JOHN A. WOODROW 1777 KIMBALL AVENUE WASHINGTON, DC 20004 (202) 556-1100 FAX (202) 556-1101 WWW.WOODROW-ASSOCIATES.COM</p>	<p>CHECKER JOHN A. WOODROW 1777 KIMBALL AVENUE WASHINGTON, DC 20004 (202) 556-1100 FAX (202) 556-1101 WWW.WOODROW-ASSOCIATES.COM</p>	<p>APPROVER JOHN A. WOODROW 1777 KIMBALL AVENUE WASHINGTON, DC 20004 (202) 556-1100 FAX (202) 556-1101 WWW.WOODROW-ASSOCIATES.COM</p>	<p>DATE 11/11/11</p>	<p>PROJECT NO. 1777 KIMBALL AVENUE</p>

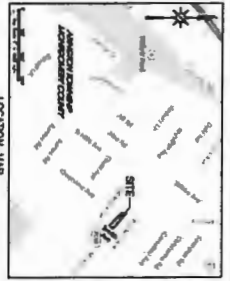

Total Project Disturbance:
15,670 S.F. or 0.3597 ACRES

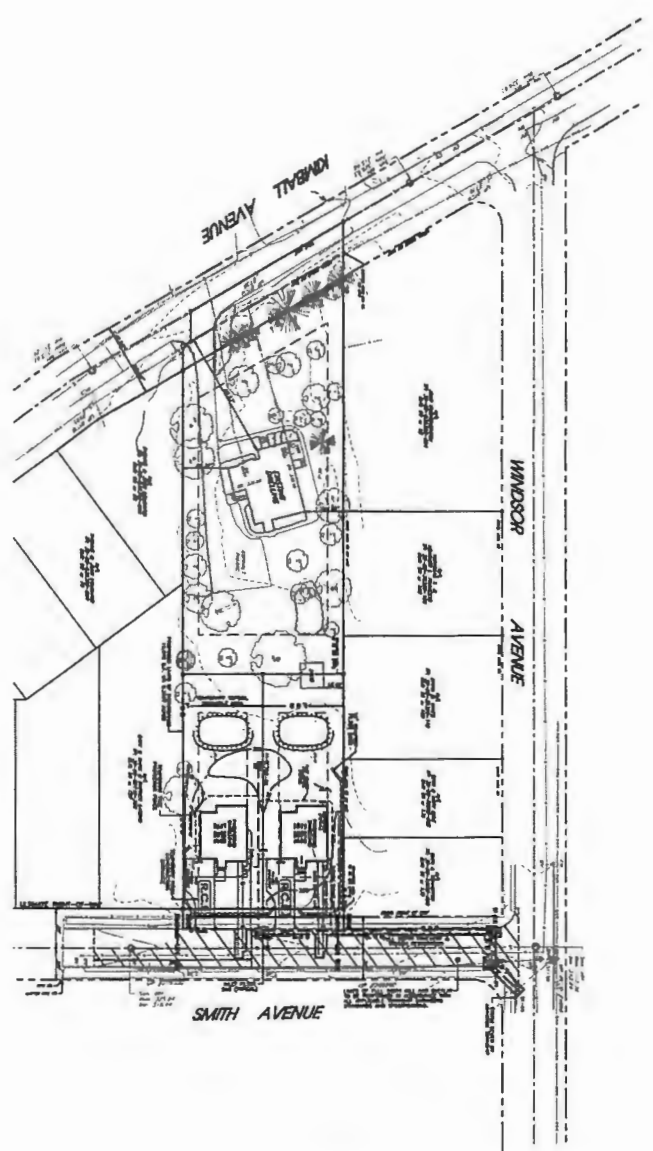

MANIPULATED LEGEND

Proposed Building	Proposed Driveway	Proposed Parking	Proposed Landscaping
Proposed Retention Wall	Proposed Erosion Control	Proposed Sediment Basin	Proposed Silt Fence
Proposed Stormwater Management	Proposed Access Road	Proposed Utility	Proposed Easement
Proposed Right-of-Way	Proposed Survey	Proposed Boundary	Proposed Easement
Proposed Easement	Proposed Easement	Proposed Easement	Proposed Easement



<p>EROSION and SEDIMENTATION CONTROL PLAN 1777 KIMBALL AVENUE</p>		<p>Project Engineer JOHN A. WOODRUFF No. 10872</p>	<p>Project Architect JOHN WOODRUFF No. 10872</p>	<p>Scale: 1" = 100'-0"</p>	<p>WOODRUFF & ASSOCIATES, INC. MUNICIPAL CIVIL CONSULTING ENGINEERS 1777 KIMBALL AVENUE, SUITE 200 WINDSOR, MA 01890 Tel: 978-335-1111 Fax: 978-335-1112</p>	<p>SEAL</p>	<p>REVISIONS</p> <table border="1"> <tr> <th>No.</th> <th>Description</th> </tr> <tr> <td>1</td> <td>Issue for Review</td> </tr> <tr> <td>2</td> <td>Issue for Construction</td> </tr> <tr> <td>3</td> <td>Issue for Construction</td> </tr> <tr> <td>4</td> <td>Issue for Construction</td> </tr> </table>	No.	Description	1	Issue for Review	2	Issue for Construction	3	Issue for Construction	4	Issue for Construction
No.	Description																
1	Issue for Review																
2	Issue for Construction																
3	Issue for Construction																
4	Issue for Construction																

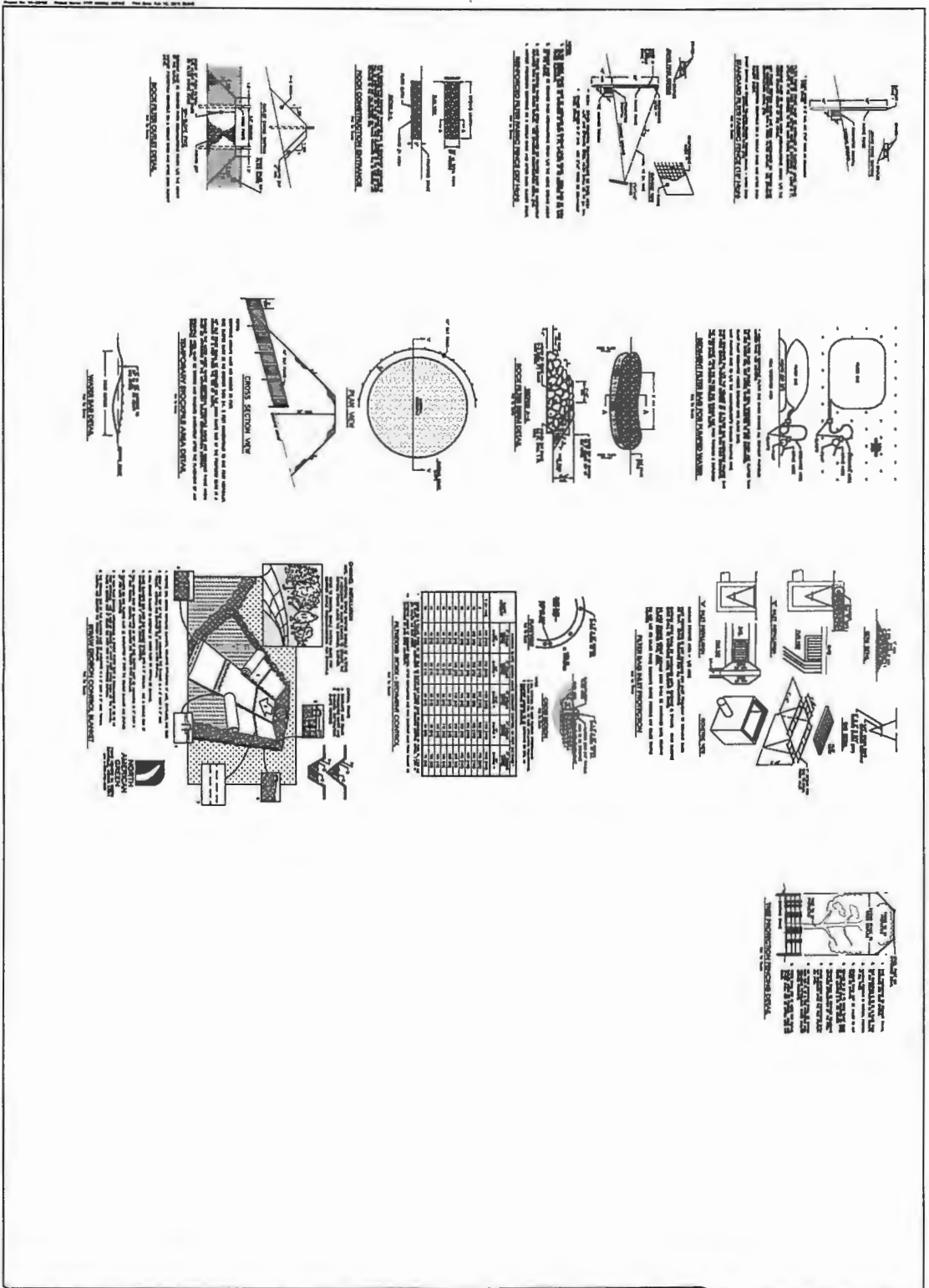

	EROSION AND SEDIMENTATION CONTROL DETAILS 177 KIMBALL AVENUE WOODROW & ASSOCIATES, INC. A NATIONAL CONSULTING CORPORATION		PROJECT NO. 177-K SHEET NO. 9
	DATE: 11/15/11 SCALE: AS SHOWN	DRAWN BY: J. B. BROWN CHECKED BY: J. B. BROWN	APPROVED BY: J. B. BROWN

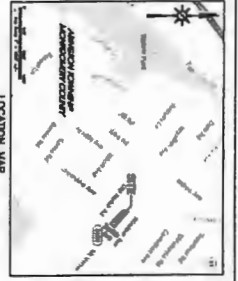

RAMP MAINTENANCE PROGRAM

The purpose of this program is to ensure that the ramp is maintained in a safe and sound condition at all times. The program shall include the following:

1. Regular inspection of the ramp for signs of wear, damage, or debris.
2. Prompt repair of any damage or wear to the ramp surface.
3. Regular cleaning of the ramp to remove snow, ice, or other debris.
4. Application of salt or other de-icing agents as needed to prevent ice buildup.
5. Regular maintenance of the ramp's drainage system to ensure proper water runoff.

PROPOSED IMPROVEMENTS

Item	Description	Quantity	Unit
1	Asphalt Paving	10,000	Sq. Yds.
2	Concrete Paving	5,000	Sq. Yds.
3	Gravel Paving	2,000	Sq. Yds.
4	Stormwater Management	1	Structure
5	Landscaping	100	Sq. Yds.

PLANTING SCHEDULE

Item	Description	Quantity	Unit
1	Planting	100	Sq. Yds.
2	Planting	200	Sq. Yds.
3	Planting	300	Sq. Yds.
4	Planting	400	Sq. Yds.
5	Planting	500	Sq. Yds.

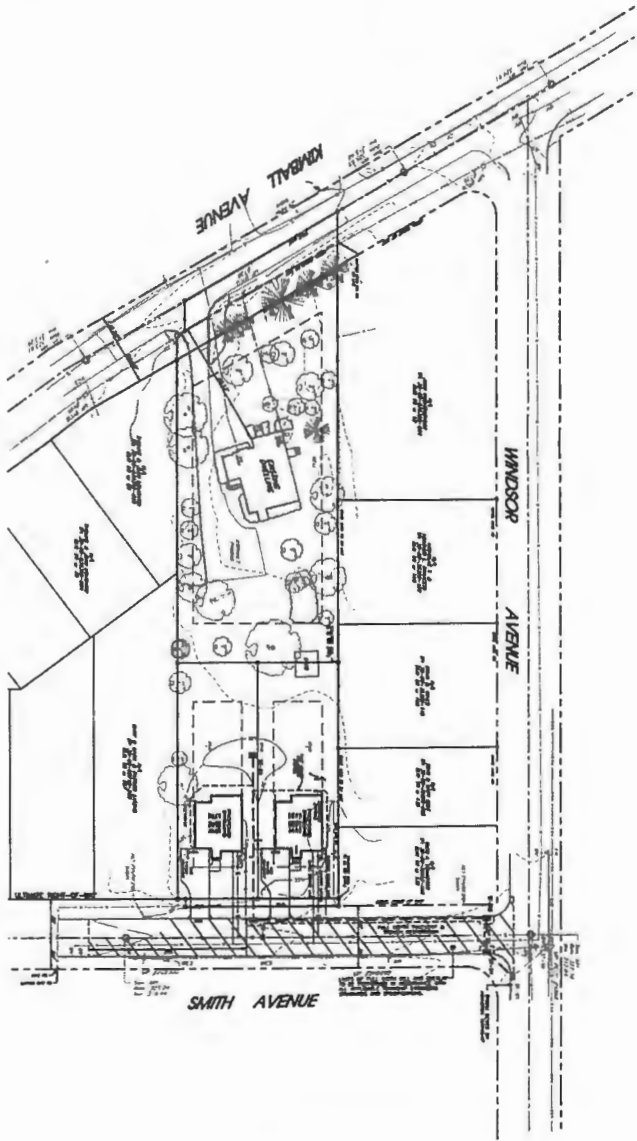

<p>WOODROW & ASSOCIATES, INC. Municipal & Civil Engineering</p>	<p>POST CONSTRUCTION STORMWATER MANAGEMENT (PCSM) PLAN 1777 KIRBALL AVENUE</p>	<p>DATE: 08-20-2014 SCALE: 1" = 20'-0"</p>	<p>PROJECT: 1777 KIRBALL AVENUE OWNER: [Redacted]</p>	<p>DESIGNED BY: JOHN J. BROWN CHECKED BY: [Redacted]</p>	<p>DATE: 08-20-2014 SCALE: 1" = 20'-0"</p>	<p>PROJECT: 1777 KIRBALL AVENUE OWNER: [Redacted]</p>	<p>DESIGNED BY: JOHN J. BROWN CHECKED BY: [Redacted]</p>	<p>DATE: 08-20-2014 SCALE: 1" = 20'-0"</p>	<p>PROJECT: 1777 KIRBALL AVENUE OWNER: [Redacted]</p>	<p>DESIGNED BY: JOHN J. BROWN CHECKED BY: [Redacted]</p>
	<p>NO. OF SHEETS: 7 SHEET NO.: 7</p>	<p>DATE: 08-20-2014 SCALE: 1" = 20'-0"</p>	<p>PROJECT: 1777 KIRBALL AVENUE OWNER: [Redacted]</p>	<p>DESIGNED BY: JOHN J. BROWN CHECKED BY: [Redacted]</p>	<p>DATE: 08-20-2014 SCALE: 1" = 20'-0"</p>	<p>PROJECT: 1777 KIRBALL AVENUE OWNER: [Redacted]</p>	<p>DESIGNED BY: JOHN J. BROWN CHECKED BY: [Redacted]</p>	<p>DATE: 08-20-2014 SCALE: 1" = 20'-0"</p>	<p>PROJECT: 1777 KIRBALL AVENUE OWNER: [Redacted]</p>	<p>DESIGNED BY: JOHN J. BROWN CHECKED BY: [Redacted]</p>



GENERAL PLAN AND SITE LOCATION

THIS LANDSCAPE ARCHITECTURE PLAN WAS PREPARED BY THE ARCHITECT AS PART OF THE ARCHITECTURAL PLAN FOR THE PROJECT DESCRIBED ABOVE. THE ARCHITECT'S OBLIGATION IS LIMITED TO THE DESIGN AND CONSTRUCTION OF THE LANDSCAPE ARCHITECTURE PLAN. THE ARCHITECT DOES NOT GUARANTEE THE ACCURACY OF THE INFORMATION PROVIDED HEREON. THE ARCHITECT IS NOT RESPONSIBLE FOR ANY ERRORS OR OMISSIONS IN THIS PLAN OR FOR ANY DAMAGE TO PERSONS OR PROPERTY ARISING FROM THE USE OF THIS PLAN. THE ARCHITECT'S LIABILITY IS LIMITED TO THE DESIGN AND CONSTRUCTION OF THE LANDSCAPE ARCHITECTURE PLAN. THE ARCHITECT DOES NOT GUARANTEE THE ACCURACY OF THE INFORMATION PROVIDED HEREON. THE ARCHITECT IS NOT RESPONSIBLE FOR ANY ERRORS OR OMISSIONS IN THIS PLAN OR FOR ANY DAMAGE TO PERSONS OR PROPERTY ARISING FROM THE USE OF THIS PLAN.

LANDSCAPING REQUIREMENTS

Item	Description	Quantity
1	Planting of 10 trees	10
2	Planting of 20 shrubs	20
3	Planting of 50 ground covers	50
4	Planting of 100 flowers	100

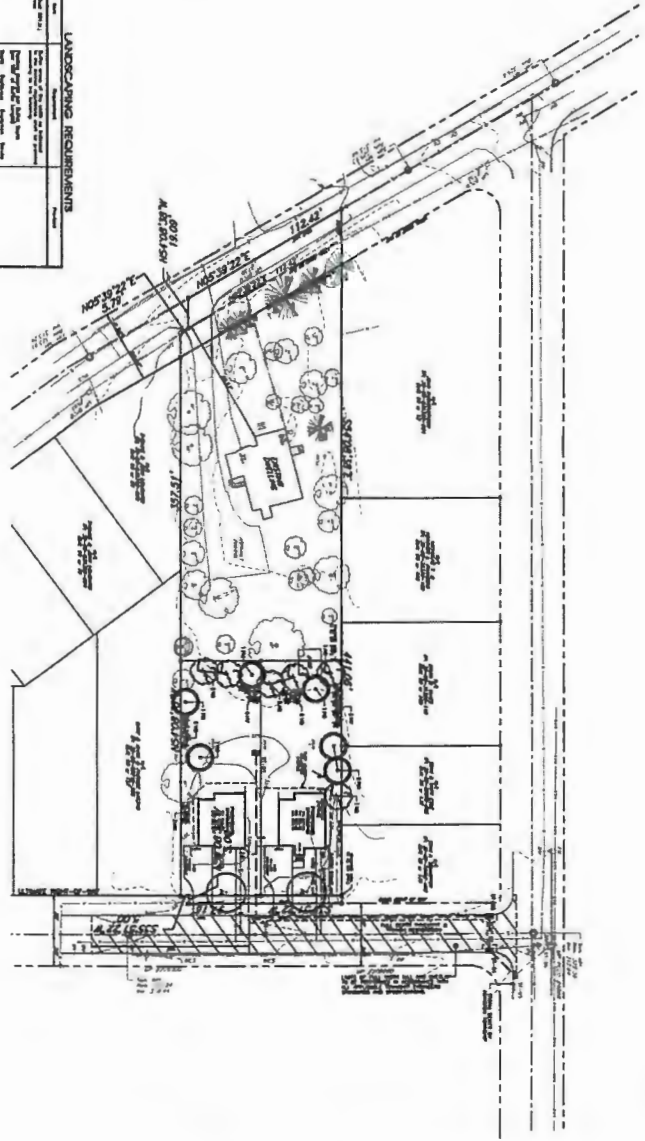

PLANTING SCHEDULE

Plant	Quantity	Plant	Quantity
1	10	1	10
2	20	2	20
3	50	3	50
4	100	4	100

PLANT MATERIALS LIST

1. Planting of 10 trees

2. Planting of 20 shrubs

3. Planting of 50 ground covers

4. Planting of 100 flowers

LANDSCAPING PLAN
1777 KIMBALL AVENUE
WOODROW & ASSOCIATES, INC.
 1000 15th Street, Suite 100, San Francisco, CA 94103
 Tel: 415.774.1111 Fax: 415.774.1112

PROJECT NO. 1000
DATE: 10/15/05

SCALE: 1" = 20'-0"

WOODROW & ASSOCIATES, INC.

8

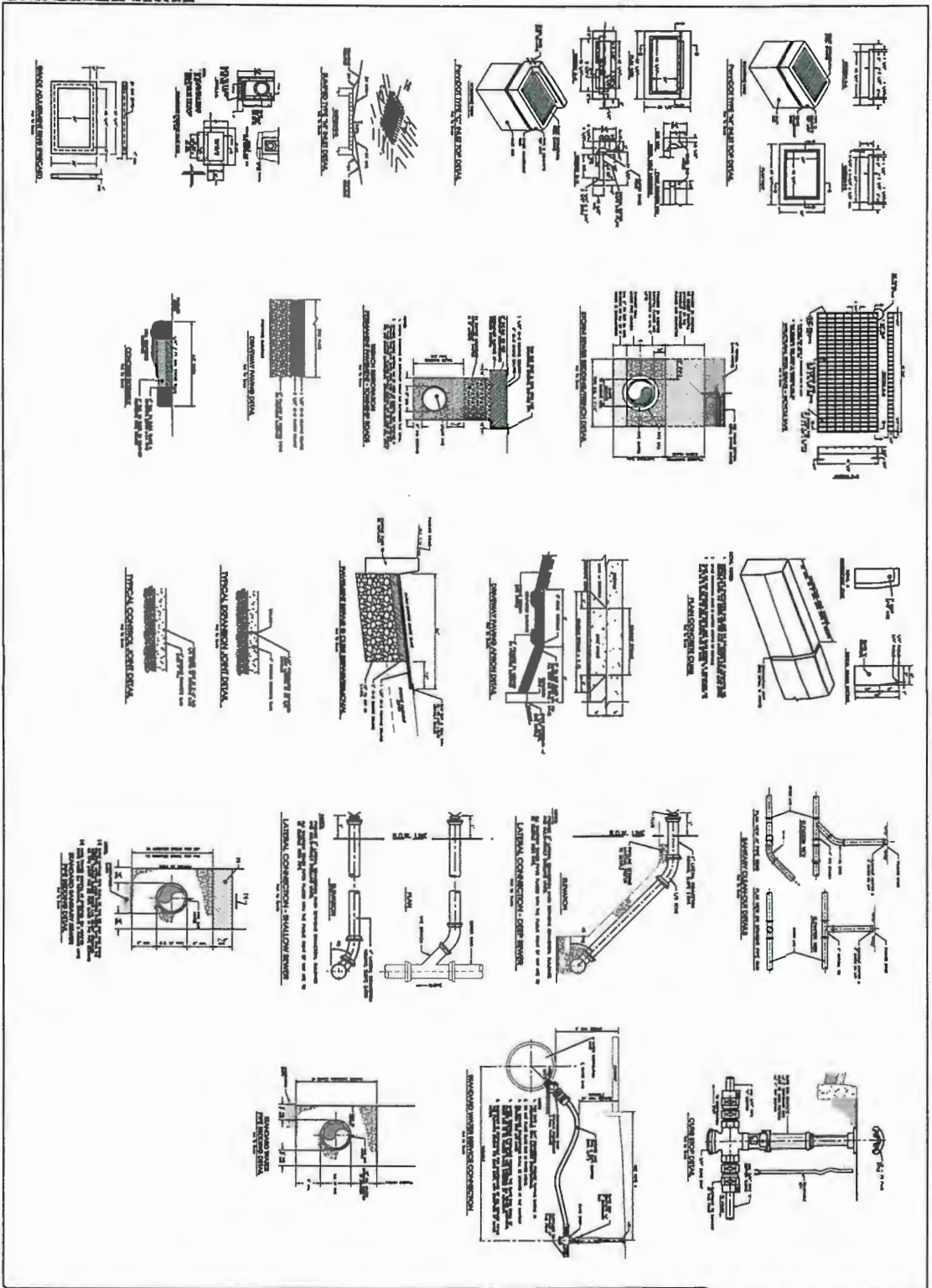

	CONSTRUCTION DETAILS SHEET "A" 1777 KIMBALL AVENUE WOODROW & ASSOCIATES, INC. ARCHITECTURAL, CIVIL, CONSTRUCTION AND INTERIOR DESIGN		
	PROJECT NO. 1111 SHEET NO. 6 DATE: 11/11/11	DRAWN BY: J. SMITH CHECKED BY: M. JONES APPROVED BY: R. BROWN	

Code Enforcement & Land Development BOARD ACTION REQUEST

March 12, 2015

CE 2

Agenda Item

CODE ENFORCEMENT

TOWNSHIP MANAGER



AGENDA ITEM
Land Development LD-15-02
Molly Court Associates, LLC.
720 Rhoads Avenue



PREVIOUS ACTION:

- Abington Township Planning Commission approved this application with conditions and requested waivers on February 24, 2015.
- Montgomery County Planning Commission approved this application on February 20, 2015.

RECOMMENDED BOARD ACTION:

Motion to approve the subdivision and land development application of **Molly Court Associates, LLC**, applicant and owner of the property located at 720 Rhoads Avenue. The applicants seek approval to demolish the existing structures on the site and subdivide the property into eight lots. A new road is proposed with access to Rhoads Avenue. The eight proposed lots will range in size from 15,098 square feet to 18,292 square feet. The applicant proposes to construct a new single-family dwelling on each of the lots. The properties are zoned in the (R-2) Residential District in Ward No. 3 of the Township of Abington.

This motion is subject to the following conditions:

1. The applicant is required to provide the Township with eight (8) new executed, signed, notarized and recorded deeds. This is a requirement of the subdivision process.
2. The applicant is required to set eight (8) concrete monuments as directed by the Abington Township Engineering Office.
3. Any work proposed within the roadway will require a "Highway Permit" from the Township Engineer's Office.
4. The items listed within the Staff Review letter dated February 2, 2015 become a condition of the application.

5. The applicant has submitted an ACT 537 Exemption application for the seven (7) new EDU's that will be required for this proposal.

This motion is subject to the following waivers:

1. Waiver from Section 146-11.A – Property Identification Plan
2. Waiver from Section 146-11.B – Existing Features Plan
3. Waiver from Section 146-11.F.b – Street Plan
4. Waiver from Section 146-11.I – Phasing Plan
5. Waiver from Section 146-11.J – Recreation Facilities Plan
6. Waiver from Section 146-11.L – Architectural Plan

COMMENTS:

- *The Township scheduled a second neighborhood meeting with the residents to address their concerns regarding landscaping and buffering.*
- *The applicant will reschedule an inspection of the property for the purpose of documenting the historical elements of the main dwelling unit, the barn and other accessory building on the site.*
- *The propose street light poles and fixtures must be approved by the Public Works Department.*
- *Any changes to the number of trees being removed from the site, must be clearly shown on the landscape plan and that revised plan be submitted for review and approval.*

Township of Abington Planning Commission Recommendation Form

Application Number: LD-15-02

Date: February 24, 2015

Applicant's Name: Molly Court Associates, Inc.

Applicant's Address: 720 Rhoads Avenue, Rydal, Pa. 19046

Recommendation: APPROVED DENIED **VOTE:** 5 of 1

Over View: This is the subdivision & land development application of **Molly Court Associates, LLC**, applicant and owner of the property located at 720 Rhoads Avenue, Rydal, Pa. 19046. The applicants seek approval to demolish the existing structures on the site and subdivide the property into eight lots. A new road is proposed with access to Rhoads Avenue. The eight proposed lots will range in size from 15,098 square feet to 18,292 square feet. The applicant proposes to construct a new single family dwelling on each of the lots. The properties are zoned within the (R-2) Residential District of Ward #3 of the Township of Abington.

Comments:

1. Sanitary sewer service is available for this development as the flow from this proposal is not impeded by the sanitary sewer moratorium in place on flows through Cheltenham Township. An Act 537 Exemption Application will need to be approved for this development. A letter of sanitary sewer availability has been submitted.
2. If this application is approved, the applicant is required to provide the township with eight (8) new, executed (signed, notarized and recorded) deeds. This is a requirement of the subdivision process. The Township Engineer will not sign the plans without the required deeds.
3. The applicant is required to set concrete monuments as directed by the Engineering Office of the Township of Abington. In addition, the staff review letter contained requirements of inspection and job completion escrows that must be submitted this this office.

4. The items listed within the Staff Review letter dated February 2, 2015 become a condition of this application if approved by the Board of Commissioners of the Township of Abington.
5. The applicant has submitted an ACT 537 Exemption application for the seven (7) new EDU's that will be required for this proposal.

The following waivers have been requested.

- A. **Section 146-11.A - Property Identification Plan** – The plan is required to supply the tax parcel information, owner's name & lot area for all properties within 400 feet of the site(s) involved in this application. Staff supports this waiver. Yes {X} No { } 5 -1
- B. **Section 146-11.B – Existing Features Plan** – The plan is required to plot the location of all utilities on the sites and within 400 feet of the properties involved in this application. Staff supports this request. Yes {X} No { } 5 -1
- C. **Section 146-11.F.b – Street Plan** – The applicant is required to submit a horizontal plan of the proposed street construction and design. Yes {X} No { } 5 -1
- D. **Section 146-11.I – Phasing Plan** – The applicant's plans do not indicate that the proposed development will be phased out over a defined timeline. Yes {X} No { } 5 - 1
- E. **Section 146-11.J – Recreation Facilities Plan** - A waiver is required from this section of the ordinance. No portion of this site is proposed to be restricted as common open space. Yes {X} No { } 5 -1
- F. **Section 146-11.L – Architectural Plan** – The applicant is required to submit tentative architectural plans. The application has submitted a floor plan of the proposed new module home, however no elevation plans have been submitted. Staff supports this waiver request. Yes {X} No { } 5 – 1
- G. **Section 127-27 – Street Improvements** – The applicant has requested a waiver from the installation of sidewalks along the proposed new roadway and also Rhoads Avenue.

Conditions:

1. The Township of Abington schedule a second neighborhood meeting with the residents to address their concerns regarding landscaping and buffering.
2. The applicant schedule an inspection of the property for the purpose of documenting the historical elements of the main dwelling unit, the barn and other accessory buildings on the site. The Planning Commission should be notified of this inspection as several members would like to attend.
3. The proposed street light poles and fixtures must be approved by the Director of the Public Works Department.
4. In the event that there is any changes to the number of trees being removed from the site. Those changes be clearly shown on the landscape plan and that revised plan be submitted for review and approval.

Notes:

1. The vote was five (5) to one (1) on all of the waiver requests and the recommendation.
2. There was much discussion on tabling the application until such time that second neighborhood meeting had taken place and the historical inspection was completed. The feeling is that post meeting, additional changes would be made to plan.

MAPenecale
2/24/2015



Wayne C. Luker, President
Steven N. Kline, Vice President
Michael LeFevre, Manager
Jay W. Blumenthal, Treasurer

1176 Old York Road Abington PA 19001-3713 Telephone: 267-536-1000

Subdivision & Land Development Notice Plan Review LD-15-02

Notice is hereby given that the Township of Abington will hold the following public meetings at the Abington Township Administration Building (1176 Old York Road) Planning Commission, Code Enforcement Committee and Board of Commissioners, to discuss the application of the **Molly Court Associates, LLC**.

MEETINGS	DATE AND TIME
Planning Commission Committee	February 24, 2015 @ 7:30 p.m.
Code Enforcement Committee	March 2, 2015 @ 7:00 p.m.
Board of Commissioners	March 12, 2015 @ 7:30 p.m.

This is the subdivision & land development application of **Molly Court Associates, LLC**, applicant and owner of the property located at 720 Rhoads Avenue, Rydal, Pa. 19046. The applicants seek approval to demolish the existing structures on the site and subdivide the property into eight lots. A new road is proposed with access to Rhoads Avenue. The eight proposed lots will range in size from 15,098 square feet to 18,292 square feet. The applicant proposes to construct a new single family dwelling on each of the lots. The properties are zoned within the (R-2) Residential District of Ward #3 of the Township of Abington.

The application and plans are on file in the Code Enforcement Department and may be reviewed upon request. If there are any questions and/or comments that you may have, please feel free to contact me at 267-536-1017.

Mark A. Penecale
Planning & Zoning Officer

- *These meetings are subject to change if additional review time is required by Township Staff or requested by the applicant.*



**MONTGOMERY COUNTY
BOARD OF COMMISSIONERS**

JOSH SHAPIRO, CHAIR

VALERIE A. ARKOOSH, MD, MPH, VICE CHAIR

BRUCE L. CASTOR, JR., COMMISSIONER



**MONTGOMERY COUNTY
PLANNING COMMISSION**

MONTGOMERY COUNTY COURTHOUSE • PO Box 311
NORRISTOWN, PA 19404-0311
610-278-3722

FAX: 610-278-3941 • TDD: 610-631-1211
WWW.MONTCOPA.ORG

JODY L. HOLTON, AICP
EXECUTIVE DIRECTOR

February 20, 2015

Mr. Mark A. Penecale, Zoning Officer
Abington Township
1176 Old York Road
Abington, Pennsylvania 19001-3713

Re: MCPC #15-0015-001
Plan Name: 720 Rhoads Avenue
(8 lots/8 units comprising 3.41 acres)
Situate: Rhoads Avenue (S)/West of Essex Road
Abington Township

Applicant's Name and Address

Molly Court Associates, LLC
1525 Campus Drive
Warminster, PA 18974

Contact: Adam Reiff
Phone: 215-672-8000

Dear Mr. Penecale:

We have reviewed the above referenced Subdivision and Land Development Plan in accordance with Section 502 of Act 247, "The Municipalities Planning Code," as you requested on January 22, 2015. We forward this letter as a report of our review and recommendations.

Background

The applicant proposes to subdivide a 3.41 acre property into eight lots. The new lots would vary in size from 15,098 s.f. to 18,292 s.f. The property is the site of an existing 2.5-story, 2,968 s.f. stone dwelling (constructed c.1740, according to County Board of Assessment data), existing 2-story stone and wood barn (constructed c.1800 also according to County Board of Assessment data), a utility shed, and a pool. The applicant proposes demolition of all of these. The property lies in the R2 Low-Medium Density Residential District. The applicant proposes public water and sewer. The applicant has submitted a Preliminary and Final Plan dated January 14, 2015.

Review Comments

Historic Preservation –

1. Is anything known about the historic significance of the home and barn? If historically significant, has the applicant considered retaining either or both as part of an estate lot, considered moving the structure(s), or considered salvaging or donating significant architectural features or materials? The Township might investigate whether it would be possible to work with the property owner to document the property, inside and out, prior to demolition (in part through photographs).

2. We know the Township is considering creating an historic preservation ordinance in the future. Should this structure/these structures be historically significant, an historic preservation ordinance would enable the Township to require many of the ideas in paragraph 1, above, or require a waiting period prior to demolition to enable a future historic preservation commission to suggest alternatives to demolition, including historic reuse of the structure(s).

Sidewalks – We recommend having a sidewalk constructed on one side of the proposed Molly Court at this time.

Landscaping –

1. The applicant proposes 10 street trees of the same species; we recommend some diversification for visual interest and reduction of vulnerability to disease or pests over time.
2. The plan shows a woodland area preserved by the applicant that extends along most of the property line between Lots 7 and 8. This is a bit misleading; there are only two trees in that area proposed for preservation.

Plan Information – The landscaping plans shall be prepared by a registered landscape architect [§146-11.H].

Recommendation

We recommend approval of this subdivision and land development provided the proposed plan complies with your municipal land use regulations and all other appropriate regulations.

Please note that the review comments and recommendations contained in this report are advisory to the municipality and final disposition for the approval of any proposal will be made by the municipality.

Should the governing body approve a final plat of this proposal, the applicant must present the plan to our office for seal and signature prior to recording with the Recorder of Deeds office. A paper copy bearing the municipal seal and signature of approval must be supplied for our files.

Sincerely,

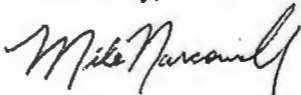

Mike Narcowich, AICP, Principal Community Planner
610.278.5238 - mnarcowi@montcopa.org

- c: Michael LeFevre, Township Manager
TEI Consulting Engineers, Inc., Applicant's Engineer
Lawrence T. Matteo, Jr., Director of Planning and Code Enforcement
Don Marquardt, Chrm., Township Planning Commission
Michael E. Powers, P.E., Township Engineer
Michael P. Clarke, Esq., Township Solicitor

Attachment: Reduced copy of applicant's plan

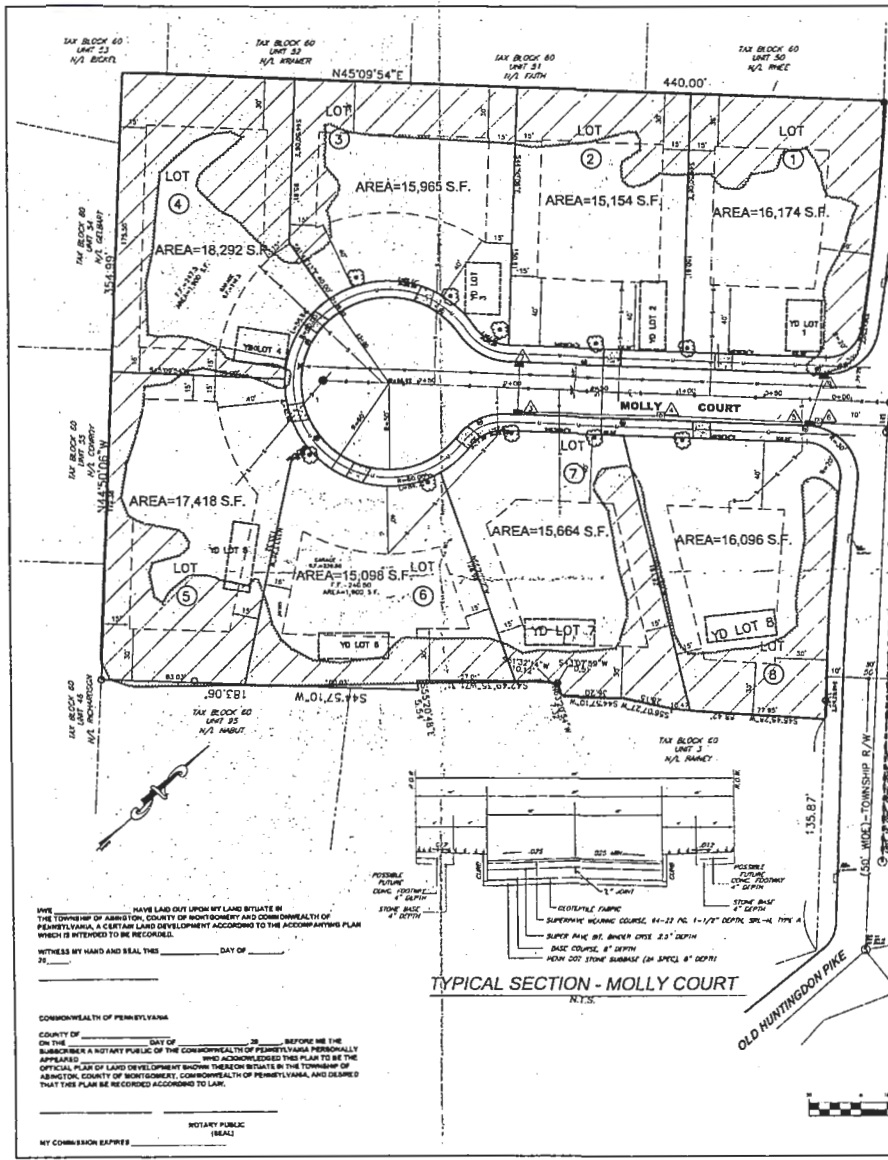

GENERAL NOTES

- TRACT IDENTIFICATION**
TAX BLOCK 60 UNITS 2 & 3
PARCEL NO. 300048164001 & 300048168006
 - OWNER:**
MOLLY COURT ASSOCIATES, LLC
1823 CAMPUS DRIVE
WARRMINSTER, PA. 19374
 - SITE ADDRESS**
720 RHOADS AVE.
JENKINTOWN, PA. 19046
TOTAL LOT AREA 151,605 S.F. OR (3.4818 AC.)
 - ZONING REQUIREMENTS**
ZONED RESIDENTIAL LOW MEDIUM DENSITY (R-2) DISTRICT
- | REGULATIONS | REQUIRED |
|--------------------------|-------------|
| MIN. LOT AREA | 15,000 S.F. |
| MIN. LOT WIDTH AT BLDG. | 100 FT. |
| MIN. LOT DEPTH | 100 FT. |
| MIN. FRONT YARD | 40 FT. |
| MIN. SIDE YARD | 10 FT. |
| MIN. REAR YARD | 30 FT. |
| MAX. BUILDING HEIGHT | 35 FT. |
| MAX. BUILDING LENGTH | 150 FT. |
| MAX. BUILDING SEPARATION | 30 FT. |
| MAX. BUILDING COVERAGE | 25 % |
| MAX. IMPERVIOUS COVERAGE | 25 % |
| MIN. GREEN AREA | 65 % |
- 30 FT. FOR A LOT ON A CUL-DE-SAC BULB
- PROPOSED LOTS**
8 LOTS ARE PROPOSED AS FOLLOWS:
- | LOT | AREA S.F. |
|-----|-----------|
| 1 | 16,174 |
| 2 | 15,154 |
| 3 | 15,965 |
| 4 | 16,282 |
| 5 | 17,418 |
| 6 | 15,098 |
| 7 | 15,866 |
| 8 | 15,096 |
- TOTAL 129,811
AVG. LOT 16,223
- | TOTAL SITE | 151,605 (3.48 AC.) |
|------------|--------------------|
| LOTS | 129,811 (2.98 AC.) |
- NEW STREET 21,794 (317 L.F.)
EXIST. IMP. 11,725 (0.27 AC.)
PROP. IMP. IN STREET 16,225 (0.35 AC.)
PROP. IMP. ON LOT 18,400
- TREE PROTECTION AREA 47,042 S.F. (1.08 AC.) OR 36 % OF SITE
- THE R/W AREA IS TO BE DEDICATED TO THE TOWNSHIP.

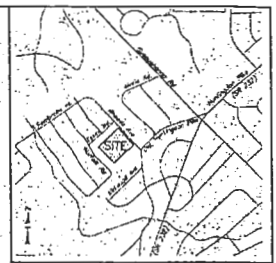

GENERAL NOTES (CONTINUED)

- PROTECTED TREE AREA**
ONE OF THE PROJECT GOALS IS TO PRESERVE AS MANY EXISTING TREES AS POSSIBLE. THEREFORE, A TREE PROTECTION AREA HAS BEEN CREATED. NO EXISTING TREES CAN BE REMOVED IN THIS 47,042 S.F. AREA.
- SIDEWALKS**
THE PROPOSED STREET WILL CONTAIN CURBS AND GRADED SIDEWALK AREA TO MAINTAIN THE EXISTING RURAL FLAVOR OF THE NEIGHBORHOOD. IT IS PROPOSED TO GRADE THE SIDEWALK AREAS WITH LAWN AS THE SURFACE. IF IN THE FUTURE A NEED FOR SIDEWALK IS DEVELOPED, ONLY THE CONCRETE HAS TO BE ADDED.
• SITE WILL BE SERVED WITH PUBLIC WATER AND SANITARY SEWER.
10- SURVEY MONUMENTS WILL BE SET AS REQUIRED BY TOWNSHIP ENGINEER.
11- STREET LIGHTING AND STREET TREES WILL BE PROVIDED.

REVIEWED BY THE TOWNSHIP ENGINEER THIS DAY OF 2010

APPROVED BY THE PLANNING COMMISSION OF ABINGTON TOWNSHIP THIS DAY OF 2010

APPROVED BY THE BOARD OF COMMISSIONERS OF THE TOWNSHIP OF ABINGTON THIS DAY OF 2010

RECORDED IN THE OFFICE OF THE RECORDER OF DEEDS AT WORMLETON, PENNSYLVANIA IN PLAN BOOK PAGE

NO.	DATE	DESCRIPTION
1		RECORD PLAN
2		RECORD PLAN
3		RECORD PLAN
4		RECORD PLAN
5		RECORD PLAN
6		RECORD PLAN
7		RECORD PLAN
8		RECORD PLAN
9		RECORD PLAN
10		RECORD PLAN
11		RECORD PLAN
12		RECORD PLAN

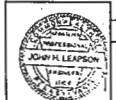

RECORD PLAN
PRELIMINARY/FINAL
SUBDIVISION/
LAND DEVELOPMENT PLAN
OF
720 RHOADS AVENUE

DATE: JANUARY 14, 2010 SHEET: 1 OF 15

TEI CONSULTING ENGINEERS, INC.
720 84 SECOND STREET PHASE
SOUTHAMPTON, PA. 18986
PHONE: (610) 382-0773
FAX: (610) 382-0744
WWW.TEICONSULTING.COM

ASSOCIATED LANDSCAPE ARCHITECT
John H. Leapan
213-341-4021 (PH)

NOTARY PUBLIC
STATE OF PENNSYLVANIA
I, _____, DO HEREBY CERTIFY THAT THE ABOVE IS A TRUE AND CORRECT COPY OF THE RECORD PLAN AS FILED IN THE OFFICE OF THE RECORDER OF DEEDS AT WORMLETON, PENNSYLVANIA ON _____ DAY OF _____, 2010.



Wayne C. Luker, President
Steven N. Kline, Vice President
Michael LeFevre, Manager
Jay W. Blumenthal, Treasurer

1176 Old York Road Abington PA 19001-3713 Telephone: 267-536-1000

John H. Leapson, PE, PLS
TEI Consulting Engineers, Inc.
720 Second Street Pike/Suite 203
Southampton, Pa. 18966

February 2, 2015

**Re: Staff Review Comment on Application LD-15-02 for the property Located at
720 Rhoads Ave., Rydal, Pa. 19046.**

Dear Mr. Leapson,

This letter is written to inform you that the staff of the Township of Abington has reviewed the Subdivision & Land Development application and the plans that have been submitted for the proposed development of 720 Rhoads Road, Rydal, Pa. The plan proposes the subdivision of the property into eight parcels. The plan proposes the construction of eight new single family dwelling, new roadway, street lighting, fire hydrant and shade trees. Several of the items listed below are building permit related issues and are noted for your review and information only. They will be clearly marked within this letter as (BP) and will be addressed at the time a building permit would be submitted in the event that this application is approved.

Engineering:

1. The sanitary sewers flow from this proposed subdivision & land development are not affected by the DEP/Cheltenham Township moratorium.
2. If this application is approved, the applicant is required to provide the Township with nine new executed "signed, notarized and recorded" deeds. Eight deeds for the proposed new parcels and one deed for the dedication of the road. This is a requirement of the subdivision process. The Township Engineer will not sign the final plan unless this is completed.
3. The Storm Water Management report and design is adequate. Prior to a construction permit is issued, the applicant is required to apply for a SWM permit from the Engineer's Office. The application fee for said permit is \$110.00 for each system. The applicant will also need to provide an escrow in the sum of \$250.00 for inspection of the on-site storm system for the next five years. That is eight lots at \$250.00 per lot for a total of \$2,000.00. Each seepage pit will be the responsibility of the property owner and will be inspected yearly by the Township.
4. A Construction Permit from the Township Engineer's Office will be required for the inspection of the construction of sanitary sewer system, the storm water management systems, curbing, paving and concrete monuments. This permit has a base fee of \$65.00. Based on the amount of work and amount of time we will be on-site for inspection, there is an additional \$1,500 for inspection fees.



5. Additional escrow will be necessary for construction costs. The applicant can contact the Township Engineer directly to discuss those amounts. The applicant will also need to contact the engineering department to schedule the inspection dates and times. Ultimately, the basins and the storm sewer will be the responsibility of the property owner and will be inspected by the Township on a yearly basis.
6. The applicant is required to contact any and all utilities for cancellation, removal, capping, or relocating the existing utility services prior to the demolition of the existing structures.
7. Any sanitary pipe placed within the R.O.W. & street areas shall be ductile iron pipe. Plastic/PVC is not acceptable within the R.O.W. area. The same is true for all sanitary sewer pipe that is proposed to dedicated to the Township.
8. In the event that the application is approved the applicant is required to submit a minimum of four paper, four mylar and one PDF formatted disk of the approved plan.
9. The plan does not indicate the installation of any concrete monuments. Concrete monuments are required at any and all bearing changes and lot line intersections. If this plan is approved the applicant is required to install a total of 31 concrete monuments. Contact this office directly to review this requirement.
10. The plans need to show a new manhole on Rhoads Road where the new storm water line will be connected to the existing storm sewer. The plan indicates a "Flow Control Manhole" {FCM} for the storm sewer. Detail on this manhole is required to be added to the plan. Also, the plan indicates the FLM as structure #3, a regular manhole as #7 and there is no #8, but there is a #9. We think they are mislabeled. Please review and make the necessary corrections.
11. The legend indicates a circle with an "S" as an "existing storm manhole", but the plans have that same symbol on the sanitary manholes. This will cause confusion and is required to be corrected.
12. The sanitary sewer lateral for Lot #6 encroaches into Lot #7. The applicant must either create an easement or a better idea would be to relocate the sanitary sewer line so that is contained within Lot #6.

Building Inspector:

13. Permits are required for the construction of the proposed new single family dwellings. All construction must comply with the ICC Residential Construction Code, as adopted by the Township of Abington.
14. Permits are required for all electrical, plumbing, heating, air conditioning and demolition work proposed to be completed on this site. The demolition of the existing structures will require cap-off certification/ permits and a rodent infestation certification. (BP)

15. All contractors are required to be registered with the Township of Abington and present valid insurances. (BP)

Plumbing Inspector:

16. The applicant is required to obtain permits for the proposed new work. All permits must be applied for by a Master Plumber that is registered with the Township of Abington. (BP)
17. Separate permits are required for the installation of new sanitary sewer lines. In addition, the approval of this plan will require the purchase of seven new EDU's at a cost of \$26,250.00. (BP)
18. All plumbing work must comply with the Plumbing Code of the Township of Abington. (BP)

Fire Marshal's Office:

19. The proposed fire hydrant placement is acceptable to this office.

Planning & Zoning Office:

20. This application has been reviewed as a preliminary Subdivision & Land Development application. The applicant has requested preliminary as final approval. Due to the amount of public improvements this should be a two stage approval process.
21. The plan plots the width of the roadway at 30 feet on sheet #1 and at 47 feet on sheet #4, #5, #9 and #10. Please revise the scale of those plans
22. This project will require seven (7) additional EDU's. They are available, and an ACT 537 Exemption Application has been submitted to DEP for approval. The application was reviewed and approved for sign-off by the Director of Waste Water Treatment Facility.
23. The plan plots the location of pervious paving to be included in the driveways of all eight of the proposed new homes. Has this square footage been included into the impervious coverage calculations? The new storm water ordinance requires this square footage to be included.
24. Several of trees proposed to remain on the plan have construction within the limits of their drip edge. Standard preservation practices prohibit and disturbance with the limits of the drip edge. Please review the structure placement on Lot #5 and Lot #6. Review the on-site storm water management system on Lot #4, Lot #5, Lot #7 and Lot #8.
25. A copy of the plan has been sent to the Environmental Advisory Council for review and comment. Those comments will be forwarded to you under separate cover.

26. Please provide details on the proposed street lighting to be installed. These standards and light fixtures must be approved by the Public Works Director.
27. This application will require a soil erosion permit from Montgomery County Conservation District.
28. The application submission did not include the section of what waivers the applicant will be requesting. Please page missing page of the application.
29. This application is required to obtain the following waivers from the Subdivision & Land Development Ordinance of the Township of Abington.
 - A. **Section 146-11.A - Property Identification Plan** – The plan is required to supply the tax parcel information, owner's name & lot area for all properties within 400 feet of the site(s) involved in this application. This plan should be amended to at the very least list the names of the adjoining property owners.
 - B. **Section 146-11.B – Existing Features Plan** – The plan is required to plot the location of all utilities on the sites and within 400 feet of the properties involved in this application. Staff supports this request.
 - C. **Section 146-11.F.b – Street Plan** – The applicant is required to submit a horizontal plan of the proposed improvements.
 - D. **Section 146-11.I – Phasing Plan** – The applicant's plans do not indicate that the proposed project will be phased out over a defined timeline.
 - E. **Section 146-11.J – Recreational Facilities Plan** – A waiver is required from this section of the ordinance. Staff is in favor of granting this waiver.
 - F. **Section 146-11.K – Planning Module** – The applicant is required to submit a Planning Module for review. The applicant has submitted a planning module exemption mailer that has been forwarded to DEP for review and final action.
 - G. **Section 146-11.L – Architectural Plan** – The applicant should not be required to submit an architectural plan, due to the fact that new buildings are not proposed with this plan. Staff supports this waiver.

If there are any revision to the plans or additional information you will be submitting, please feel free to direct them to my attention. If there are any questions pertaining to the comments listed above I can be reached at 267-536-1017.

Sincerely,

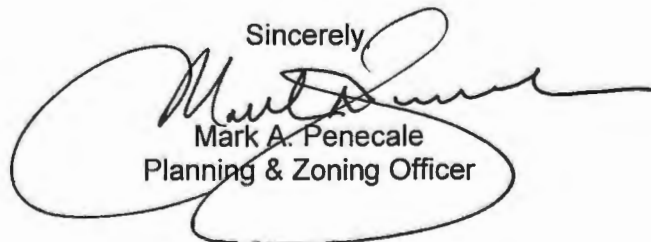

Mark A. Penecale
Planning & Zoning Officer

Cc: Adam Reiff; Molly Court Associates, 1525 Campus Drive, Warminster, Pa. 18974
Peter Friedman, Esq. 101 Greenwood Avenue, Jenkintown, Pa. 19046
Lawrence T. Matteo, Jr.; Director of Planning & Code Enforcement
Michael E. Powers; Abington Township Engineer
Bruce Hentschel; Abington Township Building Inspector
Ken Clark; Abington Township Fire Marshal
File Copy (2)



Wayne C. Luker, President
Steven N. Kline, Vice President
Michael LeFevre, Manager
Jay W. Blumenthal, Treasurer

1176 Old York Road Abington PA 19001-3713 Telephone: 267-536-1000

January 28, 2015

TEI Consulting Engineers, Inc.
720 Second Street Pike
Southampton, PA 18966

RE: 720 Rhoads Ave., Molly Court, Abington Township, PA - Sanitary Sewer Availability

Gentlemen,

The above referenced property is proposing the land development of a parcel serviced by the Abington Township sanitary wastewater collection and treatment system. An additional seven (7) single family residential homes are proposed to be added to the parcel. The existing residence is planned for demolition and will be replaced with a new residence, for a total of eight (8) additional residences connecting to the public sanitary sewer system. The sanitary wastewater from the eight homes will be conveyed to the Philadelphia Water Department's (PWD) Northeast Water Pollution Control Plant through the Abington Township conveyance system along Old Ford Road to the PWD Lorimer Park Interceptor, both of which have adequate existing capacity. The projected increase in wastewater flows will not create a hydraulic overload within the next five years.

We have the following comments pertaining to the submitted plans sheets 1 & 2 of 11 dated January 14, 2015.

1. The existing residence at 720 Rhoads Avenue is not connected to the public sanitary sewer system.
2. The existing water main along Rhoads Avenue should be indicated for the length of the property.
3. The existing storm sewer system connecting the inlets should be indicated.
4. A Plan & Profile of the proposed sanitary sewer main should be provided. The sewer main should be 8" diameter pipe and the lateral sewers from the main to the property line of each lot should be 6" diameter. The connection into the existing sewer main should be made into the existing manhole by core drilling the manhole wall and installing a modular mechanical seal such as Link Seal. Stationing should be continuous along the entire length of the sewer. Construction details should be provided.
5. All lateral sewer pipes should be located at least 10 feet from property lines, driveways, driveway aprons, trees, light poles, fire hydrants, water valves and storm sewers. Lateral pipes should be straight with no elbows or bends from the structure to the sewer main.



6. The proposed manhole in the cul-de-sac should be relocated to provide direct connections for the sewer laterals from Lot No.'s 3, 4, 5 & 6.
7. The proposed first floor elevations of each structure should be provided for each lot.
8. The Planning Module Exemption Mailer should be revised as follows:
 - a. Item 4 a should be 8 EDU.
 - b. Item 5 should be 2,120 gpd. (8 X 265 gpd/EDU)
 - c. Item 6 a should have "Public" checked.
 - d. Item 6 "Interceptor Name" should be Old Ford Road to Lorimer Park
 - e. Item 6 "Treatment Facility Name" should be PWD Northeast Water Pollution Control Plant.
 - f. Item 6 "NPDES #" should be PA0026689
 - g. Item 6 b should be N/A

A full set of revised plans should be provided for review. The associated tapping fees required for the eight (8) additional EDU's totals \$28,000.00 (8 X \$3,500.00 = \$28,000.00). There is a required plumbing fee of \$250.00 for each residential connection.

Sincerely,

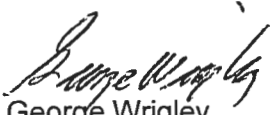

George Wrigley
Director, Abington Wastewater Utilities Department

pc: Mark Penecale, Abington Township Planning & Zoning Officer
Michael E. Powers, P.E., Abington Township Engineer

**Township of Abington
APPLICATION FOR APPROVAL OF PLAN**

Submission Date Jan. 15, 2015 Application No. LD-15-02.

To the Board of Commissioners of the Township of Abington:

The undersigned hereby makes application for approval of plan type as indicated below, under the provisions of the Code of Abington Township, Chapter 146, entitled 'The Subdivision and Land Development Regulations of the Township of Abington of 1991', and any supplements and amendments thereto.

Signature of Applicant [Signature] Signature of Land Owner [Signature]
Molly Court Associates, LLC Molly Court Associates, LLC

Title of Plan Submitted: Preliminary & Final Subdivision / Land Development Plan of 720 Rhoads Avenue

A. Plan Type:

- | | |
|---|---|
| <input type="checkbox"/> Minor Subdivision | <input type="checkbox"/> Minor Land Development |
| <input type="checkbox"/> Preliminary Major Subdivision | <input type="checkbox"/> Pre Major Land Development |
| <input type="checkbox"/> Final Major Subdivision | <input type="checkbox"/> Final Major Land Development |
| <input checked="" type="checkbox"/> Preliminary Major SD & LD | <input checked="" type="checkbox"/> Final Major SD & LD |

B. Plan Identification: Preliminary & Final Subdivision / Land Development Plan of 720 Rhoads Ave - 11 sheets, dated 1-14-2015.

Plan Dated: Jan. 14, 2015 Engineer: John H. Leapson, P.E.

Plan Proposes: Brief narrative of the proposed activity. Commercial applications to include building square footage and specific uses; Residential applicants to include number of lots and amount of dwelling unit types:

It is proposed to construct eight (8) Single Family Lots, Average Lot 16,233 S.F. Proposed Township Street Molly Court, 327' in length, total site area = 151,655 S.F. (3.48 ac.)
TAX Block 60 Units 2 + 93
Parcel No. 300048164001 + 300048168006

C. Property Identification:

Address/Location 720 Rhoads Avenue
between streets Essex Rd. and Old Huntingdon Pike

(continued on next page)

D. Applicant Identification:

Applicant Molly Court Associates, LLC
 Address 1525 Campus Drive, Warminster, PA. Phone 18974

Land Owner Molly Court Associates, LLC
 Address 1525 Campus Drive, Warminster, PA. Phone 18974

Equitable Land Owner NIA
 Address _____ Phone _____

Architect _____
 Address _____ Phone _____

Engineer John H. Leggson, TEL Consulting Engineers, Inc.
 Address 720 Second St. Pike, Southampton, PA. Phone 215-322-0272

Attorney Peter Friedman, Esq.
 Address 101 Greenwood Ave., Jenkintown, PA. Phone 215-635-7200

IMPROVEMENTS PROPOSED	UNITS	ESTIMATED COST
STREET (PAVING)	1,620 S.Y.	48,600.00
STREET SIGNS	L.S.	800.00
STREET LIGHTING	L.S.	5,700.00
CURBS	1,188 L.F.	20,196.00
STORM SEWERS	302 L.F.	27,400.00
WATER SUPPLY	320 L.F.	12,800.00
FIRE HYDRANT	1 EA.	1,800.00
SANITARY SEWERS	320 L.F.	16,400.00
SHADE TREES	10 EA.	4,000.00
TOTAL		\$ 137,696.00

RECEIVED
 JAN 15 2015
 BY: 

Review Escrow _____
 Total _____

Fees acknowledged and application accepted as complete:

 Signature of Official

1/15/15
 Date

Application Fee \$ 450.00 Check # 1360 - Rec 887490

1. Development Information

Name of Development 8 SINGLE FAMILY LOTS
Developer Name MOLLY COURT ASSOCIATES, LLC
Address 720 RHOADS AVENUE
JENKINTOWN, PA. 19046
Telephone # _____
Email TEIDAVE@COMCAST.NET

2. Location of Development

a. County MONTGOMERY
b. Municipality ABINGTON TOWNSHIP
c. Address or Coordinates _____
d. Tax Parcel # 300048164001 & 300048168006
e. USGS Quad Name _____
inches up _____ over _____
from bottom right corner of map.
f. Located in a High Quality/Exceptional Value watershed?
 Yes No

3. Type of Development Proposed (check appropriate box)

Residential Multi-Residential
Describe _____
 Commercial Institutional
Describe _____
 Brownfield Site Redevelopment
 Other (specify) _____

4. Size

a. # of lots 7 # of EDUs 7
b. # of lots since 5/15/72 1
c. Development Acreage 3+
d. Remaining Acreage 0

5. Sewage Flows 2450 gpd

6. Proposed Sewage Disposal Method (check applicable boxes)

a. Sewerage System
 Existing (connection only) New (extension)
 Public Private
 Pump Station(s)/Force Main Gravity
Name of existing system being extended
RHOADS AVENUE
Interceptor Name _____
Treatment Facility Name _____
NPDES Permit # _____
b. Construction of Treatment Facility
 With Stream Discharge
 With Land Application (not including IRSIS)
 Other
 Repair?
Name of waterbody where point of discharge is proposed
(if stream discharge)

c. Onlot Sewage Disposal Systems
(check appropriate box)
 Individual onlot system(s) (including IRSIS)
 Community onlot system
 Large-Volume onlot system
d. Retaining tanks

Number of Holding Tanks _____
Number of Privies _____

7. Request Sewage Facilities Planning Module forms in electronic format

8. Request for Planning Exemption

a. Protection of rare, endangered or threatened species
Check one:
 The "PNDI Project Environmental Review Receipt" is attached.
or
 A completed "PNDI Project Planning & Environmental Review Form," (PNDI Form) is attached. I request DEP staff to complete the required PNDI search for my project. I realize that my planning exemption will be considered incomplete and that the DEP processing of my planning exemption request will be delayed, until a "PNDI Project Environmental Review Receipt" and all supporting documentation from jurisdictional agencies (when necessary) is/are received by DEP.

Applicant or Consultant Initials JHL

b. Plot Plan Attached Site Reports Attached

c. Onlot Disposal Systems

(1) I certify that the Official Plan shows this area as an onlot service area.

(Signature of Municipal Official) / Date

Name (Print) / Title

Municipality (must be same as in 2.b.)

Telephone # _____

(2) I certify that each lot in this subdivision has been tested and is suitable for both a primary and replacement sewage disposal system.

Signature of SEO / Date

Name (Print) / Certification #

Telephone # _____

(3) I certify that each lot in this subdivision is at least 1 acre in size

(Signature of Project Applicant/Agent) / Date

d. Public Sewerage Service (i.e., ownership by municipality or authority)

Based upon written documentation, I certify that the facilities proposed for use have capacity and that no overload exists or is projected within 5 years. (Attach documents.)

(Signature of Municipal Official) / Date

Name (Print) / Title

Municipality (must be same as in 2.b.)

Telephone # _____



July 25, 2014

Steven Kozlowski
872 Jenkintown Road
Elkins Park, PA 19027

Re: Water Availability
720 Rhoads Avenue
Abington Township, Montgomery County, Pennsylvania

Dear Mr. Kozlowski:

This letter will serve as confirmation that the above referenced project is situated within Aqua Pennsylvania, Inc.'s service territory. Service would be provided in accordance with Aqua Pennsylvania Inc.'s Rules and Regulations.

Service to this project will require a main extension. Main extension projects are completed under a Builder's Extension Agreement. Under this agreement, the Builder is responsible for installing the main extension, including fire hydrants and service connections, with a pre-qualified contractor that he or she hires. In addition, the Builder is required to have his or her engineer prepare main extension plans in accordance with Aqua Pennsylvania, Inc. plan specifications and submit these plans to Aqua Pennsylvania, Inc. for review and approval. To proceed with this project please forward a full set of land development and updated main extension plans to my attention.

Once all of the requirements have been met and the main extension plans have been approved the builder will be able to enter into a Builder's Extension Agreement which will require an escrow for the cost of the main extension. Please refer to the New Business Package CD, enclosed, for the specific requirements.

Flow data information for this area, if required, can be obtained upon written request to Lisa Thomas-Oliva of our Production Department so that you may determine the adequacy of our supply for your project needs. If you have specific questions related to flow test requests, you may reach Mrs. Oliva at (610) 645-1034.

If you require further information, please contact me at (610) 645-4230.

Sincerely,

A handwritten signature in cursive script that reads "Gary J. Horne".

Gary J. Horne
New Business Representative

1067

AQUA PENNSYLVANIA, INC. - FIRE HYDRANT FLOW TEST(S)

TOWN ABINGTON TWP. DATE 11/14/2014 OPERATORS RYNKIEWICZ-MOORE
 PLATE T - 15 TIME 1:15 PM WEATHER CONDITIONS COLD

FIRE HYD. #	LOCATION	STATIC (PSI)	RESIDUAL (PSI)	NO. OUTLETS	DIAMETER (INCHES)	PITOT	FLOW * (GPM)
15-444	Pembroke Rd. & Norfolk Rd.	75	40				
15-443	Essex Rd. & Clarendon Rd.			1	2 1/2	38	1034

COMMENTS

The average static pressure for fire hydrant #15-444 is 77 PSI.

NAME	COMPANY	DATE

Please be advised that you should confirm the elevations of the above referenced fire hydrants in determining pressure and flow available to your service area. These figures show conditions at the time of the test. We do not guarantee that these pressures and flows will not vary due to change in system load. The analysis was not performed for duration, therefore Aqua Pennsylvania, Inc. does not guarantee this rate for any duration of time. If the static pressure is 85 PSI or above, confirm with Aqua Pennsylvania, Inc. New Business Rep. whether pressure reducing valves will be required.

**Calculation based on accepted AWWA Standard.

Abington Township Street Light Specifications

1. Lighting plans are to be submitted to Abington Township for review and approval.
2. An as built plan is to be submitted to Abington Township before final acceptance.
3. All wiring to be according to the National Electrical Code current for the year of installation.
4. Contractor is required to file a Service and Meter application with PECO. Energy Company.
5. Upon completion of work, job will be inspected by a licensed electrical underwriter, along with representatives from the Abington Township Street Light Maintenance Department.
6. If a pole and fixture is not a Abington Township stocked pole, a spare pole and fixture are to be delivered to Abington Township for every 12 lights or part there of, installed. (i.e. 1 – 12 lights = 1 spare, 13 – 24 = 2 etc.)
7. All new fixtures are to be LED.
8. Conduit runs are to be a minimum of Schedule 40 1 1/2 " PVC.
9. A pull box is to be installed at each light and be labeled "Street Lighting".
10. Pull boxes shall be installed flush with finished grade.
11. Conduit runs from pull box to light are to be a minimum of Schedule 40 1" PVC.
12. A 5/8" x 8' ground rod shall be placed in every pull box.
13. All exposed conduit must be steel or the use of a steel pole guard is required.
14. Power for lights is to be 240 volt, 4 wire system, 2 – Hot, 1 – Neutral, 1 – Ground.
15. Feeder wires are to be # 6 "USE" or approved other.
16. Ground wire is to be #10 "USE" green or approved other.
17. All service wires from pull box to light are to be #10 "USE" or approved other.

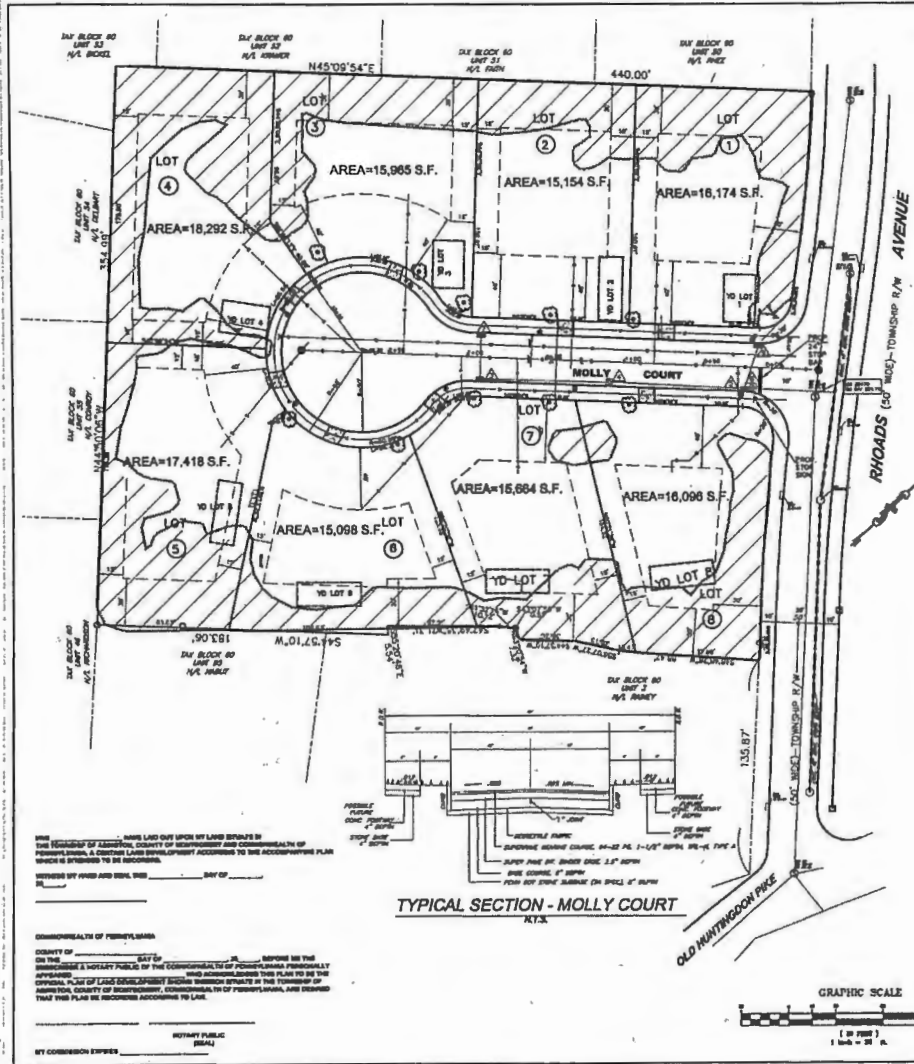

GENERAL NOTES

1. **TRACT IDENTIFICATION**
 TAX BLOCK 80 UNITS 2 & 3
 PARCEL NO. 20040210401 & 20040210500

2. **OWNER**
 MOLLY COURT ASSOCIATES, LLC
 1838 CAMPUS DRIVE
 HARTFORD, PA. 17034

3. **SITE ADDRESS**
 720 RHOADS AVENUE
 HARTFORD, PA. 17035
 TOTAL LOT AREA 14,888 S.F. OR 0.4719 AC.

4. **ZONING REQUIREMENTS**
 ZONED RESIDENTIAL LOW MEDIUM DENSITY (R-2) DISTRICT

REGULATIONS

REGULATIONS	REQUIREMENT
MIN. LOT AREA	14,888 S.F.
MIN. LOT WIDTH AT M.I.D.	100 FT.
MIN. LOT DEPTH	100 FT.
MIN. FRONT YARD	40 FT.
MIN. SIDE YARD	10 FT.
MIN. REAR YARD	20 FT.
MAX. BUILDING HEIGHT	20 FT.
MAX. BUILDING LENGTH	100 FT.
MAX. BUILDING SETBACK	20 FT.
MAX. BUILDING COVERAGE	30 %
MAX. IMPERVIOUS COVERAGE	30 %
MIN. GREEN AREA	50 %

* 30 FT. FOR A LOT ON A CUL-DE-SAC BULE

5. **PROPOSED LOTS**
 8 LOTS ARE PROPOSED AS FOLLOWS:

LOT	AREA S.F.
1	15,154
2	15,154
3	15,088
4	15,088
5	17,414
6	15,088
7	15,088
8	15,088

TOTAL 128,891
 AVE. LOT 16,111
 TOTAL SITE 14,888 (0.43 AC.)
 TOTAL LOTS 128,891 (3.70 AC.)

NEW STREET 21,734 (0.63 AC.)

EXIST. IMP. 13,736 (0.37 AC.)
 PROP. IMP. IN STREET 13,325 (0.38 AC.)
 PROP. IMP. ON LOT 15,088

THREE PROTECTION AREA 47,442 S.F. (1.08 AC.) OR 36 % OF SITE

6. THE PAV AREA IS TO BE DEDICATED TO THE TOWNSHIP.



LOCATION MAP
 SCALE: 1" = 50'

GENERAL NOTES (CONTINUED)

7. **PROTECTION TREE AREA**
 ONE OF THE PROJECT GOALS IS TO PRESERVE AS MANY EXISTING TREES AS POSSIBLE. THEREFORE, A TREE PROTECTION AREA HAS BEEN CREATED. NO EXISTING TREES CAN BE REMOVED IN THIS 47,442 S.F.

8. **BORROWINGS**
 THE PROPOSED STREET WILL CONTAIN CURBS AND GRADED SIDEWALK AREA TO MAINTAIN THE EXISTING RURAL FLAVOR OF THE NEIGHBORHOOD. IT IS PROPOSED TO GRADE THE SIDEWALK AREAS WITH LAWN AS THE BEST USE. IF IN THE FUTURE A NEED FOR SIDEWALK IS DEVELOPED, ONLY THE CONCRETE HAS TO BE ADDED.

9. SITES WILL BE SERVED WITH PUBLIC WATER AND SANITARY SEWER.

10. SURVEY MONUMENTS WILL BE SET AS REQUIRED BY TOWNSHIP ENGINEER.

11. STREET LIGHTING AND STREET TREES WILL BE PROVIDED.

DESIGNED BY THE TOWNSHIP ENGINEER THIS DAY OF _____ 2011

APPROVED BY THE PLANNING COMMISSION OF HARTFORD TOWNSHIP THIS DAY OF _____ 2011

APPROVED BY THE BOARD OF SUPERVISORS OF THE TOWNSHIP OF HARTFORD THIS DAY OF _____ 2011

RECORDED IN THE OFFICE OF THE RECORDER OF DEEDS AS INSTRUMENT NO. _____ ON THE DAY OF _____ 2011

NO.	DESCRIPTION
1	PROPOSED PLAN
2	PROPOSED SUBDIVISION
3	PROPOSED LOTS
4	PROPOSED PROTECTION AREA
5	PROPOSED SIDEWALK
6	PROPOSED STREET
7	PROPOSED IMPROVEMENT PLAN
8	PROPOSED UTILITIES
9	PROPOSED LANDSCAPE PLAN
10	PROPOSED LEGEND
11	PROPOSED LEGEND
12	PROPOSED LEGEND



RECORD PLAN
PRELIMINARY/FINAL
SUBDIVISION
LAND DEVELOPMENT PLAN
 OF
720 RHOADS AVENUE

DATE: JANUARY 14, 2011 SHEET 1 OF 11

ASSOCIATED LANDSCAPE ARCHITECT
 John H. Hays
 2710 University Plaza
 Philadelphia, PA 19104
 215-911-0200
 215-911-0201

TEI CONSULTING ENGINEERS, INC.
 708 SECOND STREET PHOENIX
 HARTFORD, PA. 17035
 PHOENIX 610-553-8072
 FAX 610-553-8066
 info@teiconsulting.com

THESE LOTS ARE OPEN TO LAND SURVEYS BY THE REGISTERED SURVEYOR OF HARTFORD COUNTY OF PENNSYLVANIA AND COMMERCIALITY OF PENNSYLVANIA. A CERTAIN LAND DEVELOPMENT ACCORDING TO THE RECORDING PLAN WHICH IS REFERRED TO BE RECORDING.

DESIGNED BY _____ DATE OF _____

APPROVED BY _____ DATE OF _____



APPROVED BY THE BOARD OF SUPERVISORS OF THE TOWNSHIP OF HARTFORD THIS DAY OF _____ 2011

RECORDED IN THE OFFICE OF THE RECORDER OF DEEDS AS INSTRUMENT NO. _____ ON THE DAY OF _____ 2011

RECORD PLAN
PRELIMINARY/FINAL
SUBDIVISION
LAND DEVELOPMENT PLAN
 OF
720 RHOADS AVENUE

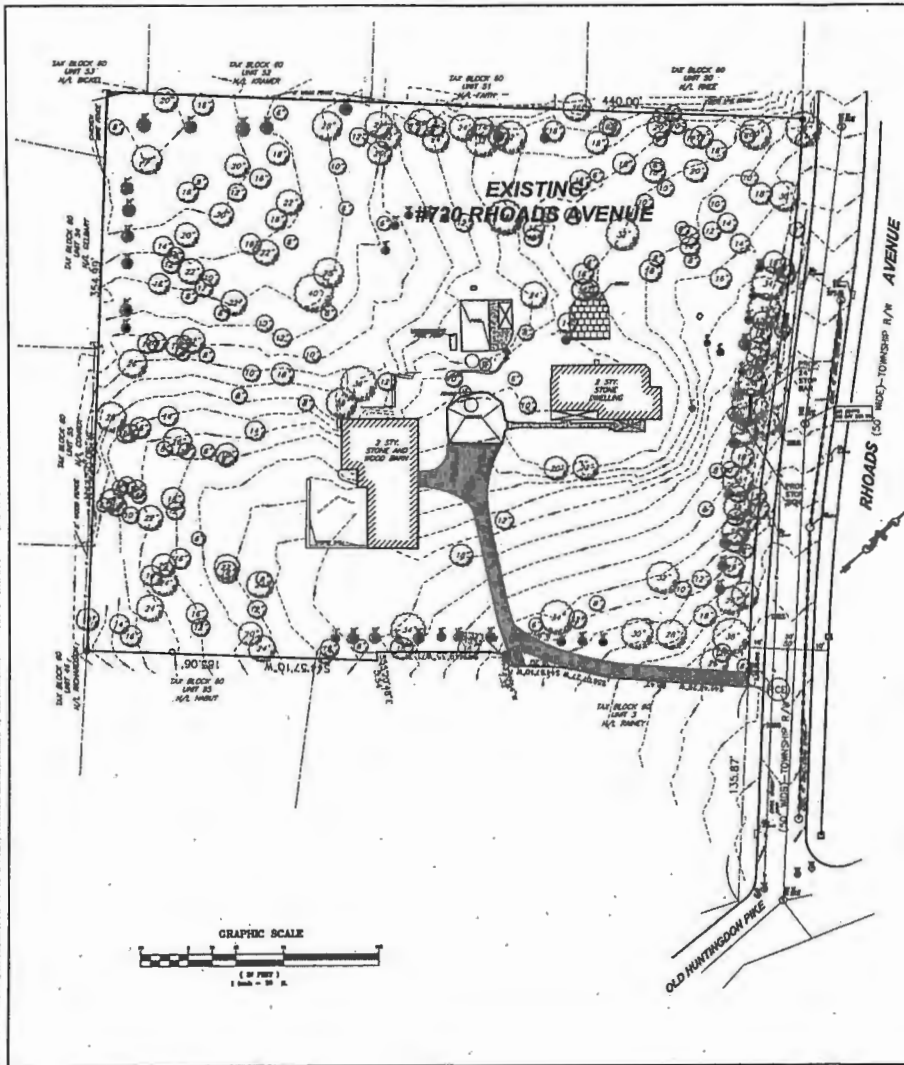
DATE: JANUARY 14, 2011 SHEET 1 OF 11



- LEGEND**
-  EXIST. BUILDING
 -  EXIST. CONCRETE PAVING
 -  EXIST. BITUMINOUS PAVING

**ONE CALL
SERIAL NO:2014-352-0469**

PUBLIC UTILITY USERS
A VERIFICATION SURVEY TO DETERMINE THE EXISTENCE LOCATION OR TYPE OF ANY UNDERGROUND UTILITY LINES OF A USER, SUCH AS A PUBLIC UTILITY HAS NOT BEEN PERFORMED.

ANYONE UTILIZING THESE DRAWINGS FOR CONSTRUCTION IS ADVISED TO CALL 1-800-348-1778 FOR UNDERGROUND UTILITIES PRIOR TO EXCAVATION IN ACCORDANCE WITH PA. ACT 172.

- COMCAST CABLEVISION
- COMCAST (WILLOW GROVE)
- ADIA PENNSYLVANIA
- VERIZON - BUSINESS
- VERIZON PA LLC
- PRCO ENERGY
- ABBINGTON TOWNSHIP



TEI CONSULTING ENGINEERS, INC.
1708 SECOND STREET WEST
HUNTSVILLE, PA. 15884
PHONE: 814.333.8277
FAX: 814.333.8448

- NOTES:**
- 1- TRACT IDENTIFICATION:
TAX BLOCK 80 UNITS 2 & 33
PARCEL NO. 300046154081 & 300046160008
 - 2- OWNER:
MOLLY COURT ASSOCIATES, LLC
1828 CAMPUS DRIVE
WARRIMSTER, PA. 18274
SITE ADDRESS:
720 RHOADS AVENUE
JENKINTOWN, PA. 19046
TOTAL AREA = 181,856 S.F. (4.1818 ACRES)
 - 3- EXISTING SITE SURVEY
EXISTING SITE SURVEY IS A CURRENT 2014 CONVENTIONAL SURVEY USING TOWNSHIP SEWER DATUM AT M.J.L. 8 2470 INVERT ELEVATION 221.73
 - 4- 11,728 S.F. (0.27) OF EXISTING IMPERVIOUS COVERAGE
 - 5- SITE IS OUTSIDE THE FEMA 100 YEAR FLOODPLAIN AS SHOWN ON FLOOD MAP PANEL 401 OF 481 PREPARED FOR MONTGOMERY COUNTY, PA., DATED DECEMBER 1994.
 - 6- SOILS DATA WAS OBTAINED FROM THE USDA/NRCS SOIL SURVEY OF MONTGOMERY COUNTY PA., DATED 2008.
ALL SOILS ON SITE ARE CLASSIFIED AS Usg1q; URBAN LAND-UDORTHETS, SCHST AND GMSB COMPLEX, 8 TO 8 PERCENT SLOPES.

**EXISTING CONDITIONS
PRELIMINARY/FINAL
SUBDIVISION/
LAND DEVELOPMENT PLAN
OF
720 RHOADS AVENUE**

BY: JOHN S. LUPTON
ABINGTON TOWNSHIP
MONTGOMERY COUNTY
PENNSYLVANIA
SCALE: 1" = 20' DATE: JANUARY 14, 2015 SHEET 1 OF 11

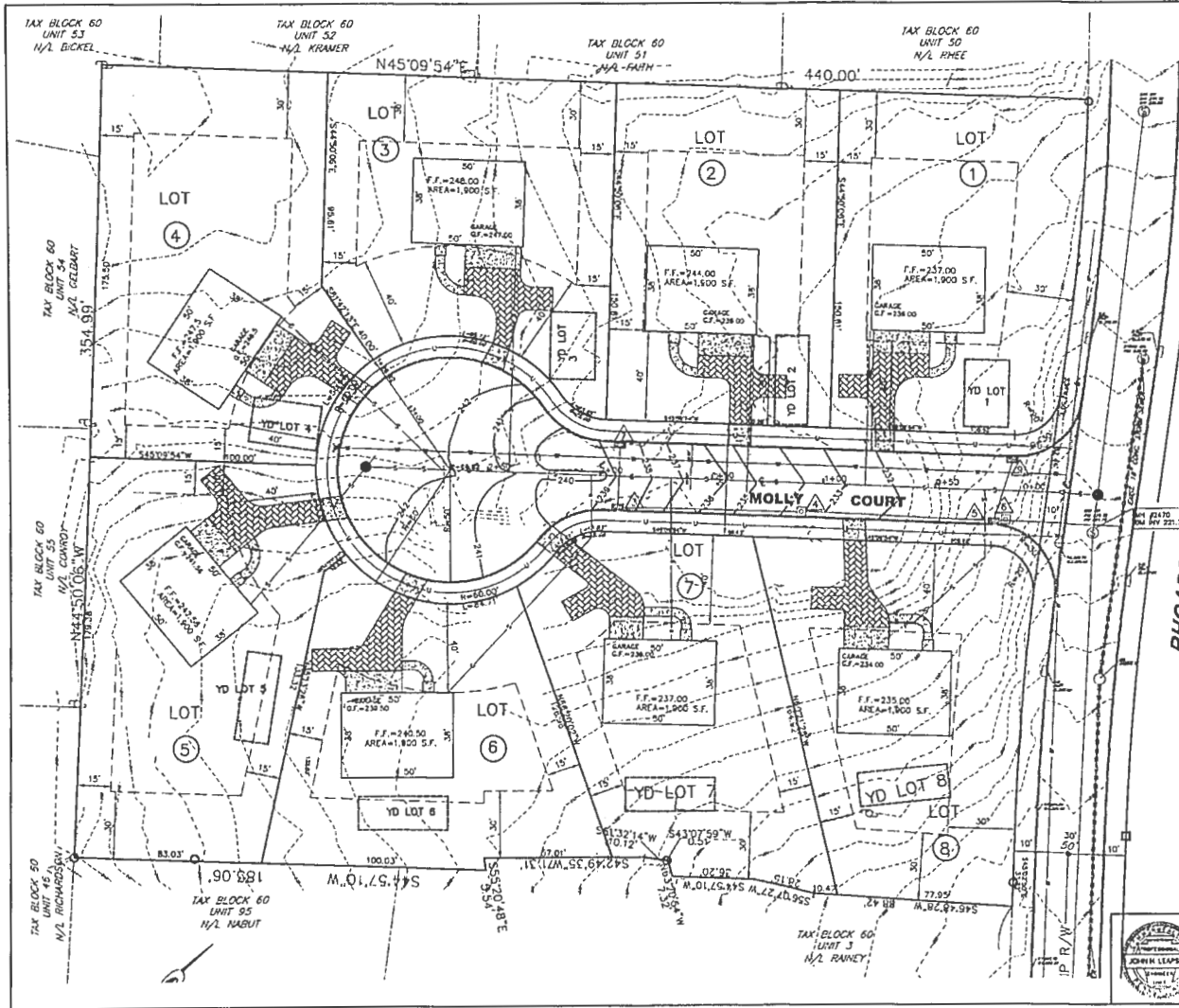

- LEGEND**
- ⊙ EXIST. STORM M.H.
 - ⊕ EXIST. WATER VALVE
 - EXIST. WATER MAIN
 - EXIST. WATER SERVICE
 - PROP. SANITARY
 - PROP. COMMON UTILITY TRENCH FOR UTILITIES TO SERVE HOUSES
 - ▨ PROP. POROUS PAVING
 - ▩ PROP. CONCRETE PAVING

STORMWATER PIPES

NO.	STRUCT.	T.O. OR B.M.	R/W.	PIPE SLOPE	REMARKS
1	12" INLET	238.6	238.6	—	
1-2	PIPE	—	—	24 L.F. OF 1% @ .81	
2	12" INLET	238.6	238.6	—	
2-3	PIPE	—	—	74 L.F. OF 1% @ .81	
3	FLOW CONTROL M.H.	234.8	232.1 IN 230.7 OUT	—	
3-4	PIPE	—	—	48 L.F. OF 1% @ .82	
4	12" INLET	231.2	231.2	—	
4-6	PIPE	—	—	3 L.F. OF 1% @ .82	
6	FLOW CONTROL M.H.	231.1	228.43 FROM 4 228.3 FROM 8	—	
6-7	PIPE	—	—	42 L.F. OF 1% @ .80	
7	M.H.	—	218.8 IN 24.8 EXIST. PIPE	—	CONSTRUCT NEW M.H. ON EXIST. 18" RCP
8	M.H.	231.8	228.84	—	
8-6	PIPE	—	—	24 L.F. OF 1% @ .81	

WATER NOTE:
 ALL WATER LINE CONSTRUCTION SHALL COMPLY WITH THE REQUIREMENTS OF AQUA PENNSYLVANIA

SAN. SEWER & STORM SEWERS NOTE:
 ALL CONSTRUCTION SHALL COMPLY WITH THE REQUIREMENTS OF ABINGTON TOWNSHIP

SITE PLAN
 PRELIMINARY/FINAL
 SUBDIVISION/
 LAND DEVELOPMENT PLAN
 OF
720 RHODS AVENUE
 WITHIN
 ABINGTON TOWNSHIP
 MONTGOMERY COUNTY
 PENNSYLVANIA
 SCALE: 1" = 80' DATE: JANUARY 14, 2011 SHEET: 2 OF 11

PREPARED BY: *John H. Leason*
 JOHN H. LEASON
 TEI CORNATY ENGINEERS, INC.
 170 BIRCH STREET, SUITE 200
 SOUTHAMPTON, PA. 18986
 PHONE: (610) 323-4071
 FAX: (610) 323-4841

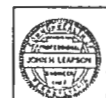
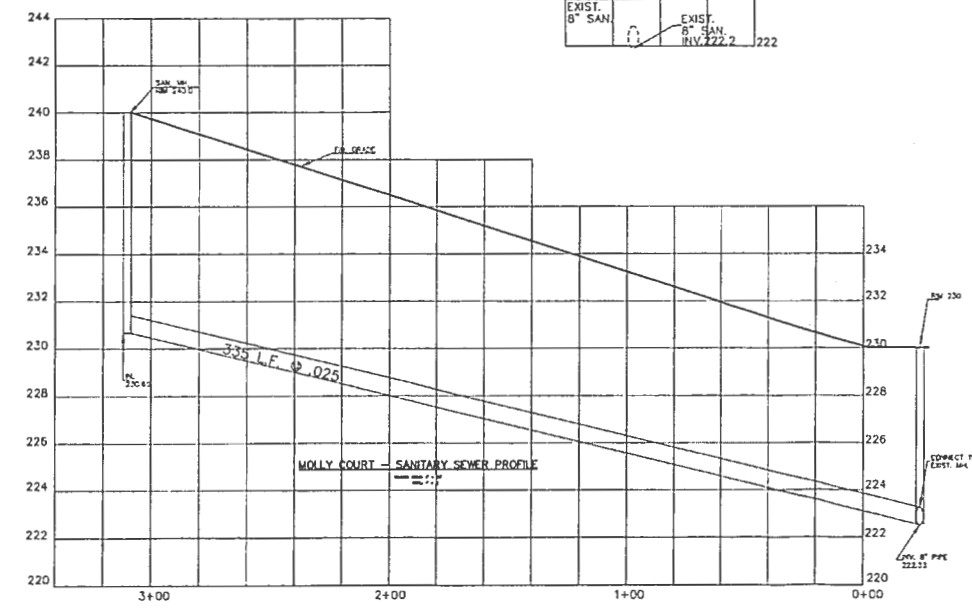
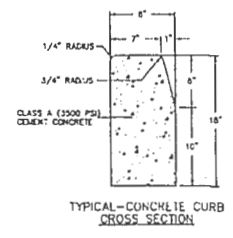
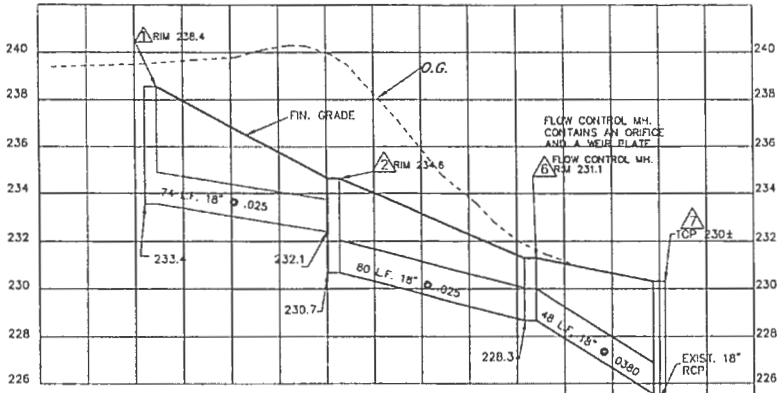

PREPARED BY *John H. Halperin*
THE CONSULTING ENGINEERS, INC.
 1701 BRIDGE STREET, SUITE 100
 SOUTHAMPTON, PA. 18986
 PHONE: 610-328-0275
 FAX: 610-328-0648

**STORM / SANITARY
 PROFILES & DETAILS**
 PRELIMINARY/FINAL
 SUBDIVISION/
 LAND DEVELOPMENT PLAN
 OF
720 RHOADS AVENUE

DATE: 01/14/2015
 ARBUSTON TOWNSHIP
 MONTCALM COUNTY
 PENNSYLVANIA

SCALE: AS NOTED DATE: JANUARY 14, 2015 SHEET 2 OF 11

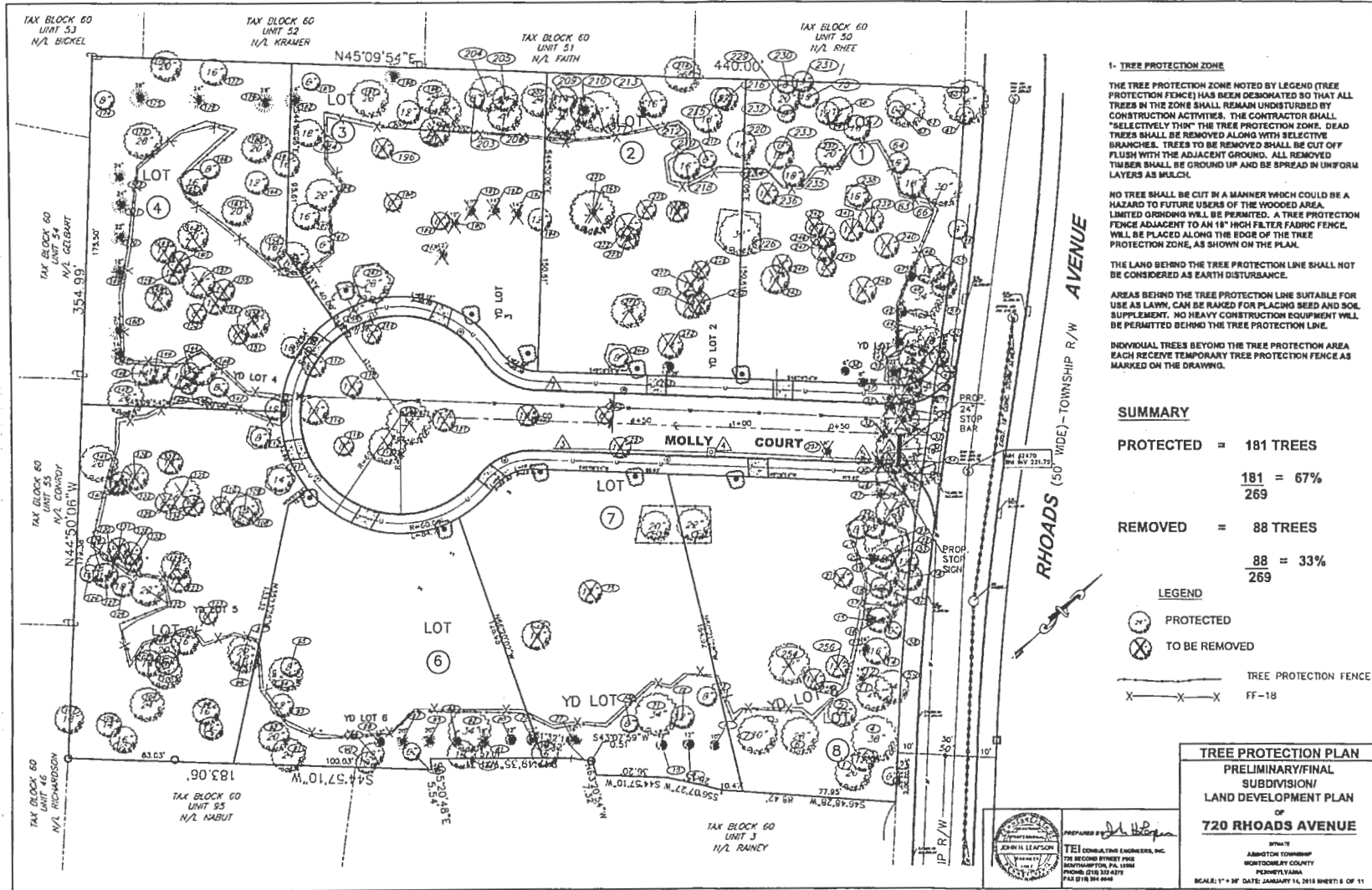

1- TREE PROTECTION ZONE

THE TREE PROTECTION ZONE NOTED BY LEGEND (TREE PROTECTION FENCE) HAS BEEN DESIGNATED SO THAT ALL TREES IN THE ZONE SHALL REMAIN UNDISTURBED BY CONSTRUCTION ACTIVITIES. THE CONTRACTOR SHALL "SELECTIVELY" THIN THE TREE PROTECTION ZONE. DEAD TREES SHALL BE REMOVED ALONG WITH SELECTIVE BRANCHES. TREES TO BE REMOVED SHALL BE CUT OFF FLUSH WITH THE ADJACENT GROUND. ALL REMOVED TIMBER SHALL BE GROUND UP AND BE SPREAD IN UNIFORM LAYERS AS MULCH.

NO TREE SHALL BE CUT IN A MANNER WHICH COULD BE A HAZARD TO FUTURE USERS OF THE WOODED AREA. LIMITED GRADING WILL BE PERMITTED. A TREE PROTECTION FENCE ADJACENT TO AN 18" HIGH FILTER FABRIC FENCE WILL BE PLACED ALONG THE EDGE OF THE TREE PROTECTION ZONE, AS SHOWN ON THE PLAN.

THE LAND BEHIND THE TREE PROTECTION LINE SHALL NOT BE CONSIDERED AS EARTH DISTURBANCE.

AREAS BEHIND THE TREE PROTECTION LINE SUITABLE FOR USE AS LAWN, CAN BE RANED FOR PLACING SEED AND SOIL SUPPLEMENT. NO HEAVY CONSTRUCTION EQUIPMENT WILL BE PERMITTED BEHIND THE TREE PROTECTION LINE.

INDIVIDUAL TREES BEYOND THE TREE PROTECTION AREA EACH RECEIVE TEMPORARY TREE PROTECTION FENCE AS MARKED ON THE DRAWING.

SUMMARY

PROTECTED = 181 TREES
 $\frac{181}{269} = 67\%$

REMOVED = 88 TREES
 $\frac{88}{269} = 33\%$

LEGEND

- PROTECTED
- TO BE REMOVED
- TREE PROTECTION FENCE
- FF-18

**TREE PROTECTION PLAN
 PRELIMINARY/FINAL
 SUBDIVISION/
 LAND DEVELOPMENT PLAN
 OF
 720 RHOADS AVENUE**

PREPARED BY: *[Signature]*
TEI CONSULTING ENGINEERS, INC.
 728 RECORD STREET, SUITE
 200, HARTFORD, PA, 17033
 PHONE: (717) 332-4272
 FAX: (717) 334-0948

BY: *[Signature]*
 ABINGDON TOWNSHIP
 MONTGOMERY COUNTY
 PENNSYLVANIA
 SCALE: 1" = 30' DATE: JANUARY 14, 2014 SHEET: 8 OF 11

PERVIOUS BLOCK PAVING

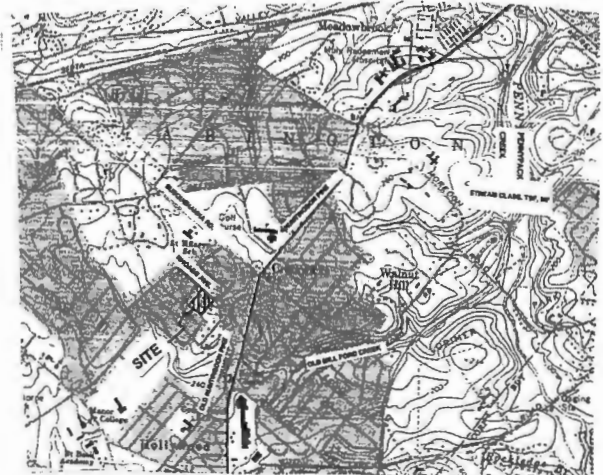
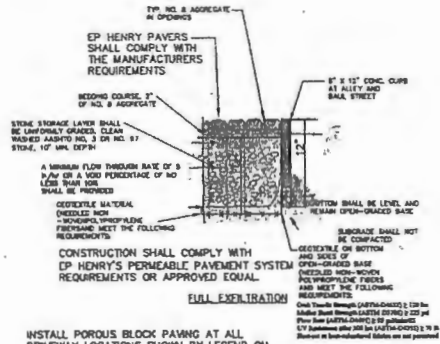

LOCATION MAP
FRANKFORD QUAD
SCALE: 1" = 100'

PERFORATED PIPE

THE UNDERGROUND SYSTEM SHALL UTILIZE HIGH DENSITY POLYETHYLENE PERFORATED PIPE MEETING THE REQUIREMENTS OF MANUFACTURER OR APPROVED EQUAL (ADVANCED DRAINAGE SYSTEMS, INC. AAS-18-03 OR EQUAL). THE SYSTEM SHALL INCLUDE MANHOLES AND FITTINGS OF THE SAME SIZE PIPE CEMENTITY AS THE PIPE. INSTALLATION SHALL BE IN CONFORMANCE WITH THE PIPE MANUFACTURER'S REQUIREMENTS.

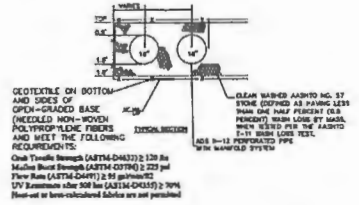

CONSTRUCT A 600 S.F. BED ON EACH LOT. INCLUDE 8 ROWS OF 18" PERFORATED PIPES. PIPE ROOF DRAINS IN SOLID 6" PVC PIPES @ .01 MIN. SLOPE.

POST CONSTRUCTION STORMWATER MANAGEMENT DETAILS
 PRELIMINARY/FINAL SUBDIVISION/ LAND DEVELOPMENT PLAN OF **720 RHOADS AVENUE**



PREPARED BY *John H. Leason*
TEI CONSULTING ENGINEERS, INC.
 178 HICKORY STREET, FIVE
 SOUTHAMPTON, PA. 18966
 PHONE: (717) 334-8873
 FAX: (717) 334-8868

ARLINGTON TOWNSHIP
 MONTGOMERY COUNTY
 PENNSYLVANIA
 SCALE: 1" = 30' DATE: JANUARY 14, 2019 SHEET: 3 OF 11

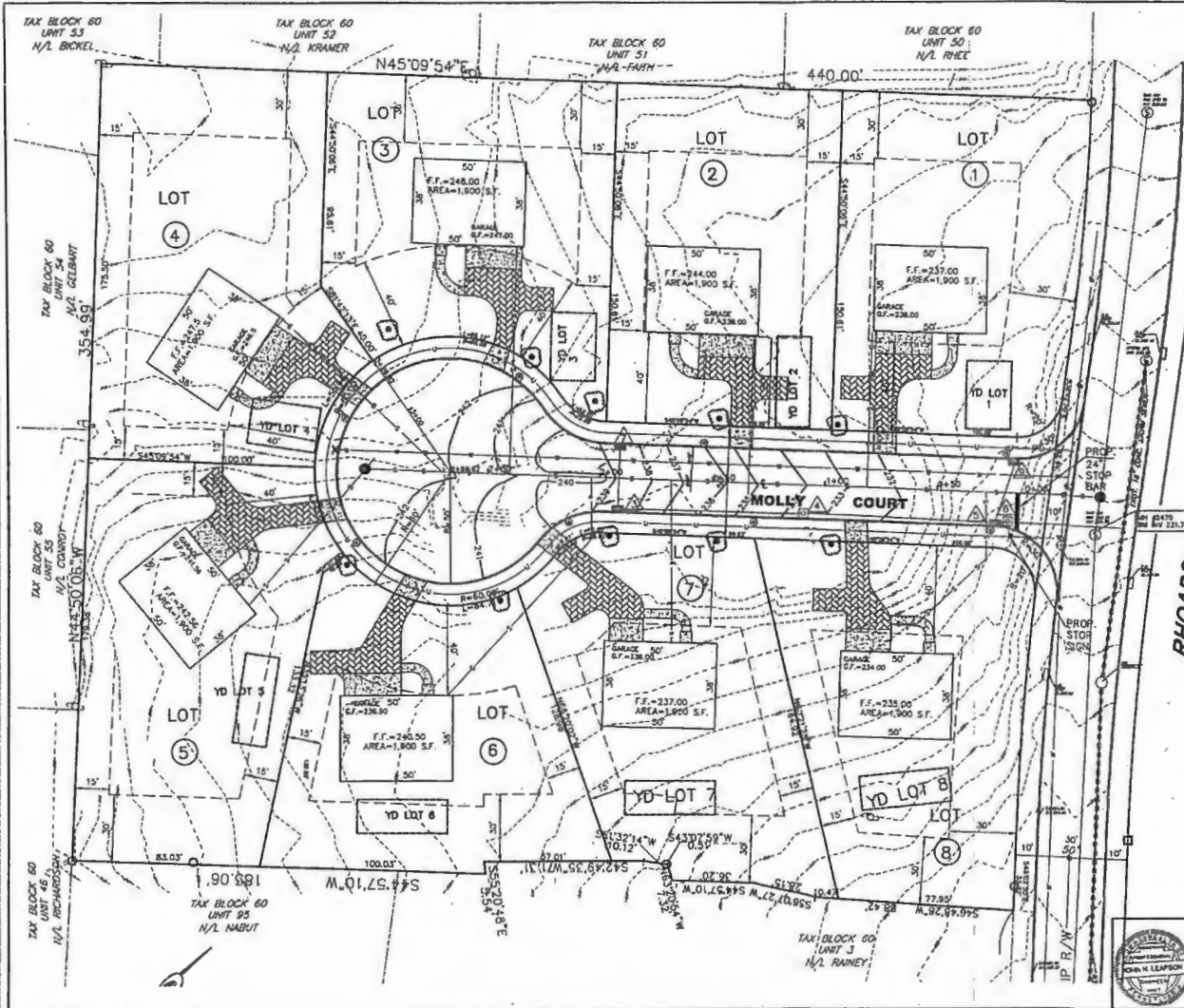

LIGHTING

PROPOSED LIGHTS (8 TOTAL) SHOWN BY LEGEND: (●)

THE DEVELOPERS CONTRACTOR SHALL INSTALL STREET LIGHTING IN MOLLY COURT IN COMPLIANCE WITH ABBINGTON TOWNSHIP REQUIREMENTS. CONTACT ED MICCIOLO FOR DETAILED INFORMATION AND COORDINATE WITH PECO.

ED MICCIOLO
PUBLIC WORKS DIRECTOR
PHONE: 267-536-1033
EMAIL: emiccio@abbington.org



LANDSCAPING AND LIGHTING PLAN

PRELIMINARY/FINAL SUBDIVISION/ LAND DEVELOPMENT PLAN OF **720 RHOADS AVENUE**

PREPARED BY: J. W. P.

TEI CONSULTING ENGINEERS, INC.
200 SECOND STREET FIVE
BOYDSTOWN, PA. 19004
PHONE: (610) 354-6771
FAX: (610) 354-6668

ABBINGTON TOWNSHIP
MONTGOMERY COUNTY
PENNSYLVANIA

SCALE: 1" = 10' DATE: JANUARY 14, 2015 SHEET: 8 OF 11

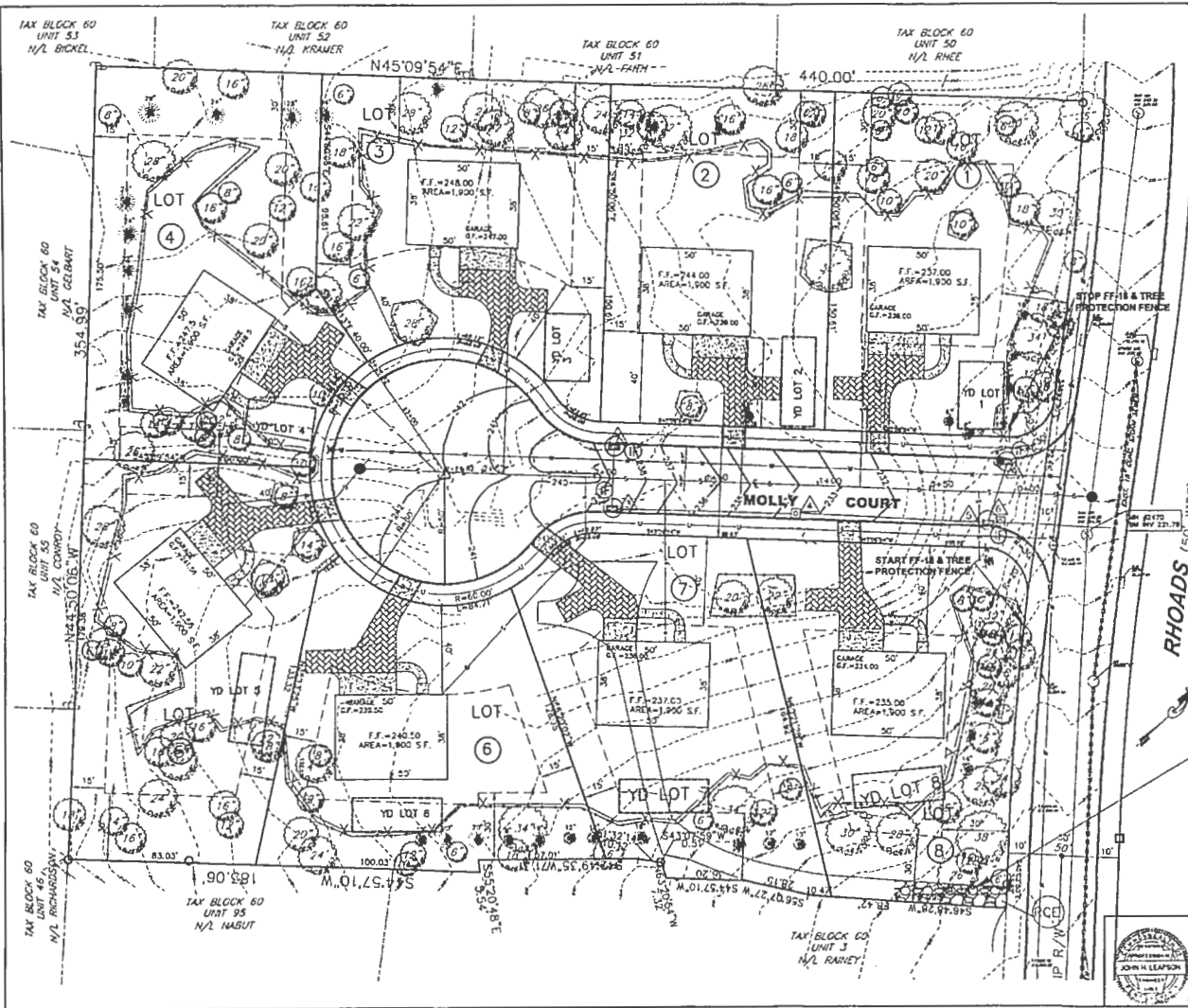

LEGEND

- [Symbol] TREE PROTECTION FENCE FF-18
- [Symbol] ROCK CONSTRUCTION ENTRANCE
- [Symbol] INLET FILTER PROTECTION

**ONE CALL
SERIAL NO:2014-352-0469**

ANYONE UTILIZING THESE DRAWINGS FOR CONSTRUCTION IS ADVISED TO CALL 1-800-242-1776 FOR UNDERGROUND UTILITIES PRIOR TO EXCAVATION IN ACCORDANCE WITH PA. ACT 172.

CONSTRUCTION ACCESS:
USE THE EXISTING BITUMINOUS DRIVE FOR THE RCE TO THE BACK AREAS FOR CONSTRUCTION ACCESS UNTIL HOLLY COURT BINDER COURSE IS BUILT. TO MINIMIZE AREA OF DISTURBANCE, AFTER THE RCE IS MOVED, MULCH THE BITUMINOUS MATERIAL AND DEPOSIT IN AN EMBANKMENT AREA.



PREPARED BY *John H. Leason*
TEI CONSULTING ENGINEERS, INC.
128 SECOND STREET WEST
BOOTHAMPTON, PA 18886
PHONE: (717) 333-8872
FAX: (717) 334-9858

**EROSION CONTROL
PRELIMINARY/FINAL
SUBDIVISION/
LAND DEVELOPMENT PLAN
OF
720 RHODS AVENUE**
871212
ARDISTON TOWNSHIP
SOUTHWEST COUNTY
PENNSYLVANIA
SCALE: 1" = 30' DATE: JANUARY 14, 2018 SHEET: 18 OF 11

... shall be installed and set in place in accordance with the following:

1. The material shall be installed in a trench 12 inches wide and 12 inches deep, with the material placed in a single layer.

2. The material shall be installed in a trench 12 inches wide and 12 inches deep, with the material placed in a single layer.

3. The material shall be installed in a trench 12 inches wide and 12 inches deep, with the material placed in a single layer.

4. The material shall be installed in a trench 12 inches wide and 12 inches deep, with the material placed in a single layer.

5. The material shall be installed in a trench 12 inches wide and 12 inches deep, with the material placed in a single layer.

6. The material shall be installed in a trench 12 inches wide and 12 inches deep, with the material placed in a single layer.

7. The material shall be installed in a trench 12 inches wide and 12 inches deep, with the material placed in a single layer.

8. The material shall be installed in a trench 12 inches wide and 12 inches deep, with the material placed in a single layer.

9. The material shall be installed in a trench 12 inches wide and 12 inches deep, with the material placed in a single layer.

10. The material shall be installed in a trench 12 inches wide and 12 inches deep, with the material placed in a single layer.

ROCK CONSTRUCTION METHODS

Approved construction methods for rock construction are as follows:

1. **CAST-IN-PLACE CONCRETE**: This method involves the use of formwork to pour concrete into a trench. The concrete is then cured and finished with a smooth surface.

2. **PRECAST CONCRETE**: This method involves the use of precast concrete blocks or panels that are assembled on-site. The blocks are set in a trench and grouted together.

3. **MASS CONCRETE**: This method involves the use of a single large concrete mass that is poured into a trench. The concrete is then finished with a smooth surface.

4. **GRAVEL**: This method involves the use of a layer of gravel to provide a drainage surface. The gravel is placed in a trench and compacted.

5. **GRAVEL WITH GEOTEXTILE**: This method involves the use of a layer of gravel with a geotextile fabric on top. The geotextile fabric is placed in a trench and the gravel is placed on top of it.

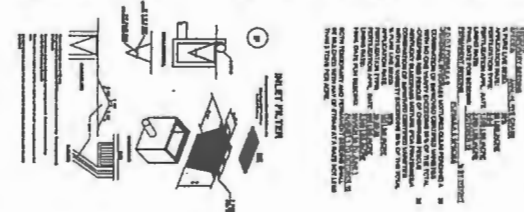

ROCK CONSTRUCTION METHODS

Approved construction methods for rock construction are as follows:

1. **CAST-IN-PLACE CONCRETE**: This method involves the use of formwork to pour concrete into a trench. The concrete is then cured and finished with a smooth surface.

2. **PRECAST CONCRETE**: This method involves the use of precast concrete blocks or panels that are assembled on-site. The blocks are set in a trench and grouted together.

3. **MASS CONCRETE**: This method involves the use of a single large concrete mass that is poured into a trench. The concrete is then finished with a smooth surface.

4. **GRAVEL**: This method involves the use of a layer of gravel to provide a drainage surface. The gravel is placed in a trench and compacted.

5. **GRAVEL WITH GEOTEXTILE**: This method involves the use of a layer of gravel with a geotextile fabric on top. The geotextile fabric is placed in a trench and the gravel is placed on top of it.

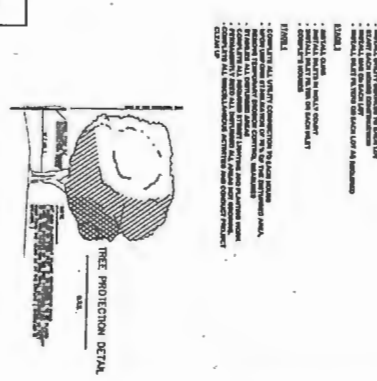
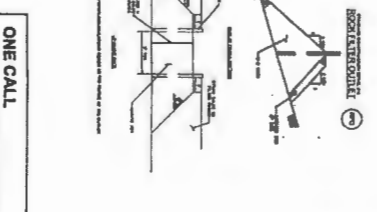

EROSION CONTROL DETAILS

PRELIMINARY/FINAL

LAND DEVELOPMENT PLAN

720 RHODAS AVENUE

PHASE I

ADDITIONAL CONSTRUCTION

REVISIONS

SCALE: AS SHOWN

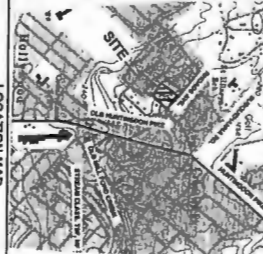

ONE CALL
SERIAL NO: 2014-352-0469

ANTHONY UTILIZING THESE DRAWINGS FOR EXCAVATION IN ACCORDANCE WITH PA. ACT 172.

600-345-1778

TEI CONSULTING ENGINEERS, INC.

ANTHONY HELEN